



Product Guide

WWW.DAKOTASTEELANDTRIM.COM

Table of Contents

3	TERMS & CONDITIONS
4	PROFILES
5	COLORS
6	DRIP STOP
8	SOFFIT
12	28 GAUGE TRIMS
25	STANDING SEAM TRIMS
33	COMMERCIAL TRIMS
40	HIGHLAND RIB TRIMS
45	LOW RIB TRIMS
48	BOARD AND BATTEN
54	T-BOARD
60	DS RESIDENTIAL PRODUCTS
65	ACCESSORIES & FASTENERS
67	RIDGE VENT & CLOSURE
71	MISC. ACCESORIES
73	SKYLIGHTS
75	CUPOLAS & WEATHERVANES
76	COM. DOOR & ACCESSORIES
84	WARRANTY INFORMATION



Terms and Conditions

By conducting business with, and placing any orders with Dakota Steel, you agree to the of terms of sale.

1. Price -- Prices are subject to adjustment by Seller in order to conform to Seller's prices in effect at date of shipment. Prices specified may not include any taxes (excise, privilege, occupation, sales, use, or other taxes payable on account), and all such taxes now in effect and/or hereafter levied which are applicable are in addition to such price and shall be paid by the Purchaser.

2. Terms of Payment---All accounts are payable in U.S. funds at the office of the Seller in Canton, South Dakota unless otherwise stated on the invoice. Payments on account by the Purchaser may, at the Seller's option, be applied on the oldest unpaid items of account in order of original date. Cash prior to credit approval by Seller's Credit Department. Purchaser's financial responsibility is always subject to approval of Seller's Credit Department. All payments shall be due at par in Canton, South Dakota in accordance with terms stated on the face of the invoice. A late charge will be assessed on delinquent balances. In the event collection of any unpaid balance is placed in the hands of attorneys, Purchaser shall pay reasonable attorney fees and costs of collection. If at any time, the financial responsibility of the Purchaser is impaired, the Seller shall have the right to cancel orders, discontinue shipments, require payments in advance and/or require other satisfactory security to guarantee that invoices will be paid promptly when due.

3. Handling and Shipment of Customer Orders---*Telephone Orders*--Purchaser assumes responsibility of the accuracy of orders placed by telephone unless a written confirmation is received prior to fabrication. When urgencies require verbal orders, your confirming order should be marked "Confirming Order-Do not Duplicate". Seller recognizes the need of filling orders promptly and agrees that it will use its best efforts to make shipments on the dates specified by Purchaser, provided such dates are reasonable; but, Seller shall not be liable for any damages for failure to make shipments on time due to fire, strikes, lockouts, differences with workmen, accidents, war, insurrection, delays in transportation, equipment failure, shortage of cars, trucks, fuel or material, governmental interference or regulation, acts of God or any other contingencies beyond Seller's control.

Delivery and Shipment--Purchaser will pay freight and transportation charges. Upon delivery of materials, FOB carrier at Seller's plant, all risk of loss, damage and other incidents of ownership shall immediately pass to Purchaser, but title to such materials will be retained by Seller as security for Purchaser's performance until payment in full is received.

4. Warranty---The following is in lieu of all warranties, express, implied, or statutory including but not limited to any express or implied warranties of merchantability or fitness for a particular purpose, warranties are made by Purchaser, or any other obligations on the part of the Seller. Seller warrants that at the time of delivery, the materials/goods delivered under this contract will conform to specifications and will be free from defects in materials and workmanship.

5. Remedies and Damages---If the materials/goods furnished by the Seller fail to conform to such warranty, Seller's sole and exclusive liability shall be to repair, replace, or upon mutual agreement to credit Purchaser's account for defective material only. If repair or replacement is made, Seller shall have reasonable time to make such repair or replacement FOB seller's plant, freight allowed. Notice of defective materials/goods must be given to Seller within ten (10) days of delivery. Final notice of any defect discoverable by inspection must be given to Seller, in writing, within thirty (30) days from date of delivery. In no event shall Seller be liable for special, incidental, or consequential damages for any breach of provisions of this contract including, but not limited to, loss of goodwill, loss of profit, loss of use or loss of crops. In the event of purchaser failure or refusal to accept materials ordered, seller may without notice retain or repossess said materials and Purchaser shall be liable for the full purchase price, less allowance for the then current value thereof at the mill after deducting freight, storage, handling and other costs.

Important Information 1. Storage---Galvalume, galvanized, and colored steel sheets have a good service life when exposed to normal weather conditions. However, these same sheets are subject to staining when water sits upon or becomes trapped between the sheets. If galvalume, galvanized, or colored sheets are to be stored for any period, they should be unbundled and stood on end against an interior wall. Metal should be spread or fanned out at their bottom ends to allow for air circulation and should be off the ground on blocks. Never cover the material with plastic as this promotes sweating. Failure to follow these steps may result in wet storage stain and premature white rusting which the manufacturer cannot be held responsible for.

2. Cutting ---When using a power saw to cut metal panels, several precautions should be taken. Place the bottom (interior) surface of the sheet up and cover with a tarp to protect the top (exterior) surface from the hot metal filings. This also reduces the chance of damage. When doing the actual cutting, be sure to wear protective eyeglasses and do it away from other unused or applied panels. Metal filings may become embedded in the surface of the actual sheet and if left alone will quickly rust. Be sure to wipe all filings from both surfaces before application.

11 Profiles

Strong Rib Panel

Available in Perforated Panel

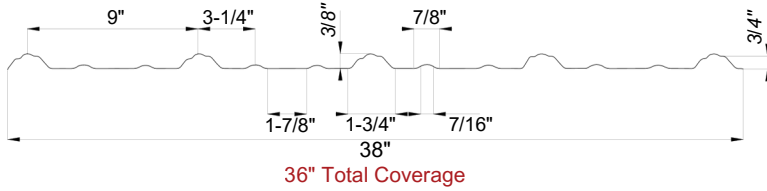

Quad Rib Panel

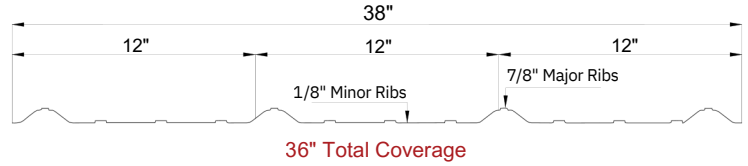

Dakota Rib Panel

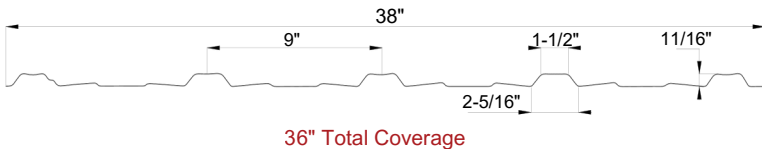

R-Panel

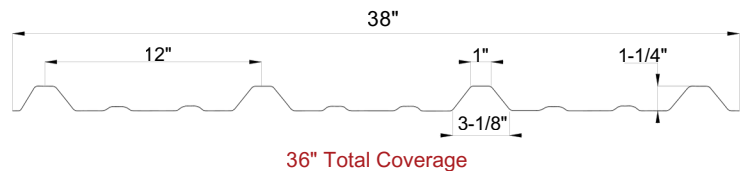

Continuous Rib Panel

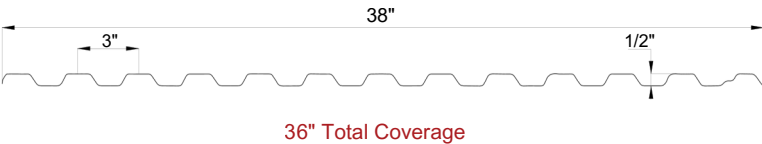

Pioneer Rib

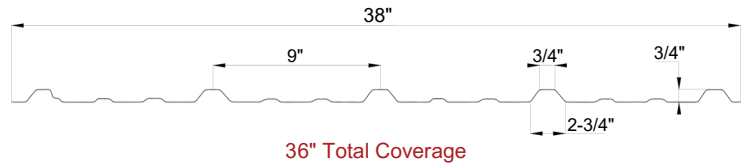

Low Rib Panel

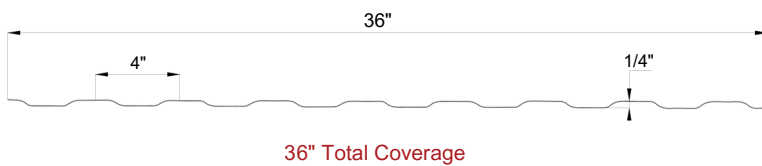

Standing Seam Panel



Highland Rib Panel

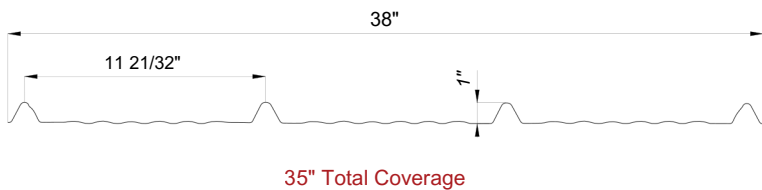

Board and Batten Panel

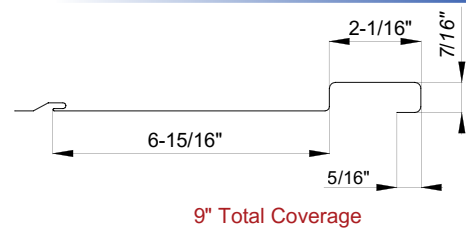

Tatanka Board (T-Board)





Colors

29 Gauge, 26 Gauge, 24 Gauge
(Trims 28 Gauge)

	STRONG RIB	PIONEER RIB	QUAD RIB	26 Gauge DAKOTA RIB	29 Gauge DAKOTA RIB	R-PANEL	26 Gauge CONTINUOUS RIB	29 Gauge CONTINUOUS RIB	LOW RIB	HIGHLAND RIB	STANDING SEAM	BOARD AND BATTEN
<i>Over 27+ Colors In Stock</i>	<i>Colors not checked may require special order.</i>											
GA - Bare Galvanized	★	★	★	★		★	★	★	★	★	★	
GV - Bare Galvalume	★	★	★	★		★	★		★	★	★	★
KW - Kestrel White	★	★	★	★	★	★	★	★	★	★	★	★
BW - Bone White	★	★	★	★	★	★	★	★	★	★	★	★
CI - Cobblestone Ivory	★	★	★	★		★	★	★	★	★	★	★
DS - Dakota Sand	★	★	★	★		★	★	★	★	★	★	★
LS - Light Stone	★	★	★	★	★	★	★	★	★	★	★	★
RH - Rawhide	★	★	★	★	★	★	★	★	★	★	★	★
CM - Clay Mist	★	★	★	★	★	★	★	★	★	★	★	★
AG - Ash Gray	★	★	★	★	★	★	★	★	★	★	★	★
SG - Smoke Gray	★	★	★	★	★	★	★	★	★	★	★	★
CG - Charcoal Gray	★	★	★	★	★	★	★	★	★	★	★	★
DG - Dakota Gray	★	★	★	★	★	★	★	★	★	★	★	★
CB - Cocoa Brown	★	★	★	★	★	★	★	★	★	★	★	★
LB - Light Brown	★	★	★	★		★	★	★	★	★	★	★
DB - Dark Brown	★	★	★	★		★	★	★	★	★	★	★
BS - Burnished Slate	★	★	★	★	★	★	★	★	★	★	★	★
RB - Roman Blue	★	★	★	★		★	★	★	★	★	★	★
GB - Gallery Blue	★	★	★	★		★	★	★	★	★	★	★
DE - Dark Blue	★	★	★	★		★	★	★	★	★	★	★
BR - Barn Red	★	★	★	★	★	★	★	★	★	★	★	★
CR - Crimson Red	★	★	★	★		★	★	★	★	★	★	★
BY - Classic Burgundy	★	★	★	★	★	★	★	★	★	★	★	★
FO - Forest Green	★	★	★	★	★	★	★	★	★	★	★	★
FE - Fern Green	★	★	★	★	★	★	★	★	★	★	★	★
BK - Black	★	★	★	★	★	★	★	★	★	★	★	★
CO - Copper Metallic	★	★	★	★		★	★	★	★	★	★	★
ALSW - Aluminum - Glossy Smooth	★	★	★									★
White Bright White Liner	★	★	★						★			
Perforated Acoustic White Liner	★	★	★						★			
AE - American Elm <i>Siding Only</i>	★											★
SF - Silver Forest <i>Siding Only</i>	★											★
IW - Iron Wood <i>Siding Only</i>	★											★
RF - Red Fawn <i>Siding Only</i>	★											★

* Direct Job-Site delivery with Forklift available upon request. *

Available in 33" Panel

Substrates

29 Gauge 26 Gauge
AZ50=2900 AZ50=2600
G60=2960 G90=2690
G90=2990

	STRONG RIB	PIONEER RIB	QUAD RIB	DAKOTA RIB	R-PANEL	CONTINUOUS RIB	LOW RIB	HIGHLAND RIB	STANDING SEAM	BOARD AND BATTEN
AZ50=2900	★	★	★			★	★	★		★
G60=2960	★	★	★	★		★	★	★		
G90=2990	★	★	★			★	★	★		
AZ50=2600	★	★	★	★	★	★	★	★	★	
G90=2690	★	★	★	★	★	★	★	★	★	
AZ50=2400	★	★	★	★	★				★	

- Copper Metallic & Dark Blue -
- 15% Premium Colors - Panels & Trims
- Bare product is Acrylic Coated G-90 Galvanized and AZ 55 Galvalume
- Check with your dealer to see what profiles may be installed on open framing or solid substrate.
- Colors checked usually stocked and available for WILL CALL production within 48 hours.
- Dakota Steel and Trim 45 Year Paint Warranty
- \$100 Per cut charge for lengths under 36"
- Minimum 36" for Low Rib & Quad Rib

(Contact local representative for details)

Some Smart Reasons to use DRIPSTOP on your next job:

Stated by Customers and Contractors

1. **"Stops Condensation"**: When temperature and humidity conditions reach the dew point, moisture condenses and is trapped. DRIPSTOP holds that moisture until conditions go back below the dew point and it is released back into the air in the form of normal humidity WITHOUT DRIPPING!

2. **"Protects your Steel"**: Rubber adhesive natural barrier against ammonia in confinements.

3. **"Saves time and money for installation"**: Applied on roof steel during manufacturing process.

4. **"Greatly reduces installation safety hazards"**: Eliminates fall hazards with installation of Double-Bubble or Fan-Fold, especially in windy conditions.

5. **"Provides natural acoustic system"**: Drip Stop absorbs significant amount of noise and greatly reduces echos.

6. **"Easy to Clean"**: You can use a high powered pressure washer to clean if necessary.

7. **"Durability"** -Won't Come Off: Birds won't be able to nest and destroy this barrier.

8. **"Anti-Microbial Design"**: Recommended for Confinements - Material engineered to resist microbial nesting.

9. **Satisfied Customers**: The most profitable business has satisfied customers!

10. **Bottom Line: Proven Quality - Performance -Satisfaction**

NOTE: DRIP STOP REQUIRES VENTILATION/AIR MOVEMENT IN ORDER TO PROVIDE AN ENVIRONMENT FOR EVAPORATION.

Without sufficient ventilation, material will become saturated beyond evaporation capacity.

USE THIS LINK: <http://www.youtube.com/watch?v=v-MOzfwZEn0>



**INSTALLATION
INSTRUCTION
TECHNICAL DATA**

Smoke generation and flamespread -UL723 approved **Capilarity**: Can wick in moisture -that is why it does not go all the way into the lap of the panel. Installer needs to seal the HORIZONTAL OVERLAPS AND EAVE OVERHANG with hot air gun ---this will fuse the fibers against wicking.

Anti-Microbial: Polyester and rubber does not provide food for fungi or microbes. Absorption: Holds up to 10 times its own weight in water ---more than 1 quart per 10 ft2

For Owners:

Condensation Control: Drip Stop effectively prevents condensation from forming on the underside of metal roofs. This is crucial in environments with significant temperature and humidity fluctuations, as it helps avoid water damage and corrosion

Mold and Mildew Prevention: By controlling moisture, Drip Stop reduces the risk of harmful bacteria growth. This is particularly important for maintaining the health of the building's occupants and preserving stored goods

Extended Roof Lifespan: The liner helps protect the metal roof from rust and other forms of deterioration caused by moisture. This can significantly extend the lifespan of your roof, saving on long-term maintenance and replacement costs

Improved Indoor Environment: It reduces rain noise and helps maintain stable indoor temperatures, enhancing comfort inside the building



For Installers:

Competitive Edge: Offering Drip Stop as part of your service can set you apart from competitors, showcasing your commitment to effective solutions

Easy To Install: Drip Stop is easy to apply during the roll-forming process, making it a convenient addition to your roofing projects

Reduce Liability: By preventing condensation and related issues, Drip Stop helps reduce potential liability for water damage and mold problems

Customer Satisfaction: Providing a solution that addresses common roofing issues, leading to happier clients and fewer callbacks

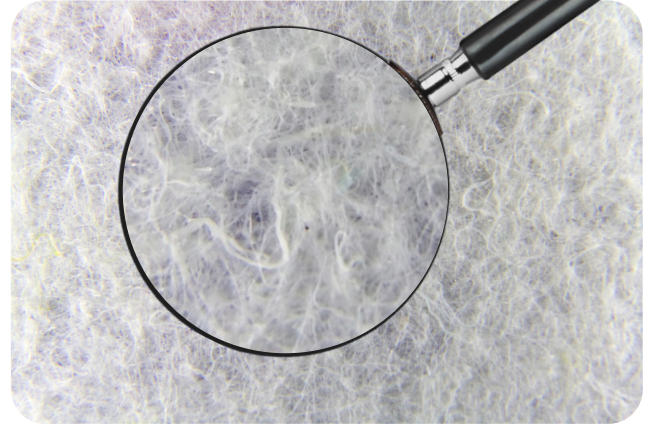
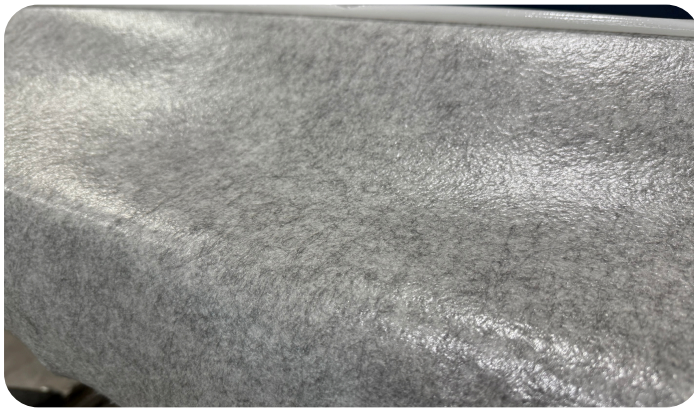

How Easy Is it to Install?

Factory-Applied: Drip Stop is applied to the metal panels during the roll-forming process at the factory. This means it arrives at the job site already attached, saving significant time and effort during installation

No Additional Tools Required: Since Drip Stop is pre-applied, there is no need for additional tools or materials to install it on-site. This simplifies the installation process and reduces the risk of errors

Durable and Tear-Resistant: The liner is designed to be resistant to ripping and tearing, ensuring it remains intact during handling and installation

Easy to Clean: Drip Stop can be easily cleaned with a hose or pressure washer, making maintenance straightforward and hassle-free

Reduces Installation Time: With Drip Stop pre-applied, simply place fasteners at the edges and overlaps, allowing for quick and easy panel installation

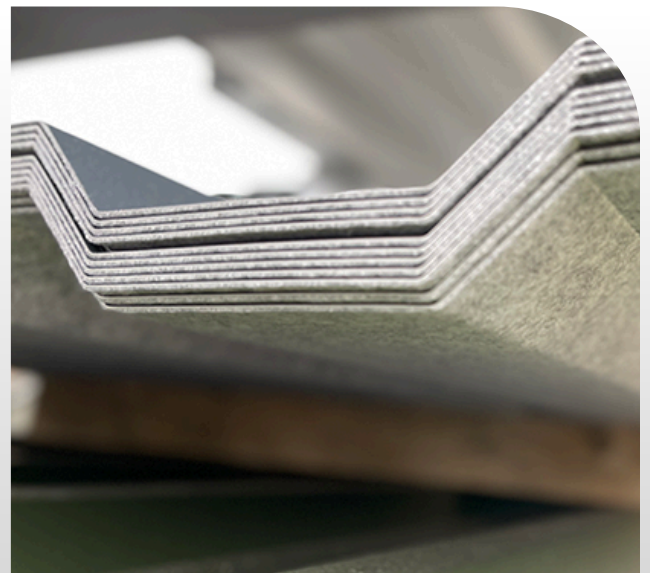

DRIPSTOP cannot be applied to Low Rib, Dakota Rib, Continuous Rib, Highland Rib, Standing Seam, Soffit, and Board and Batten in the Dakota Steel & Trim, Inc. offering

Quad Soffit - Aluminum

Solid

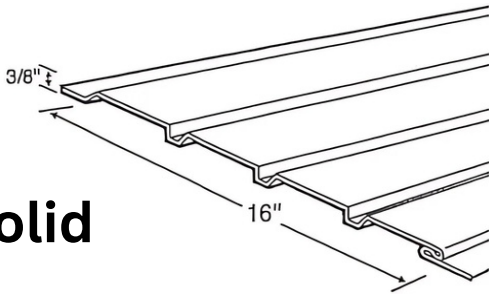

Center Vented

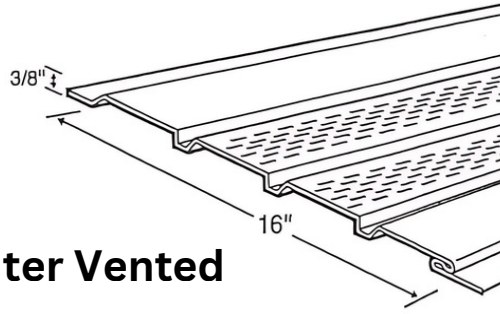

Specify Custom Lengths

Part No.	Length
QSALSOxx2918	Per LF
QSALCVxx2918	Per LF

Soffit Specifications:

- Standard 12' lengths
- Custom lengths available
- 11-3/4" and 23-3/4"
- Available in **27 colors**.
- NFA Ratings:
- 16" Center Vented -8 sq. in./LF -

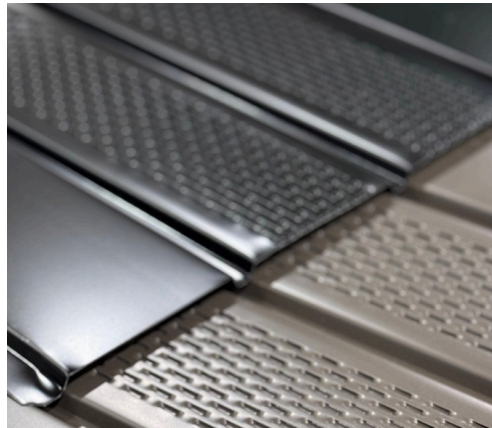
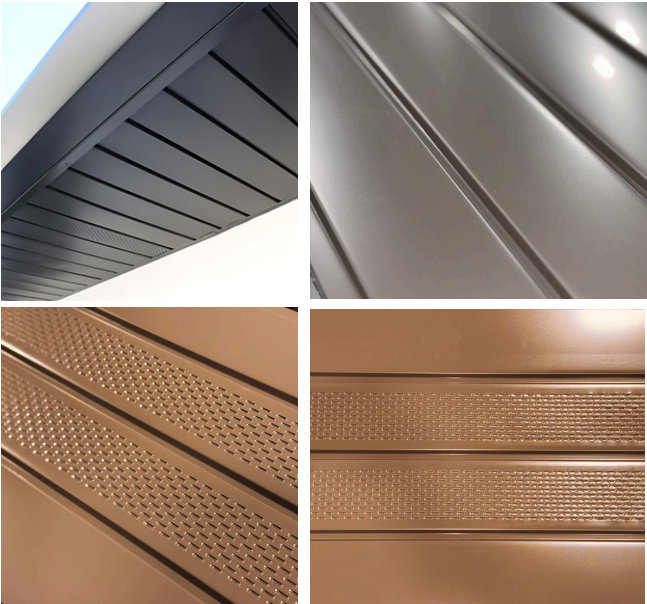

SOFFIT PROFILE

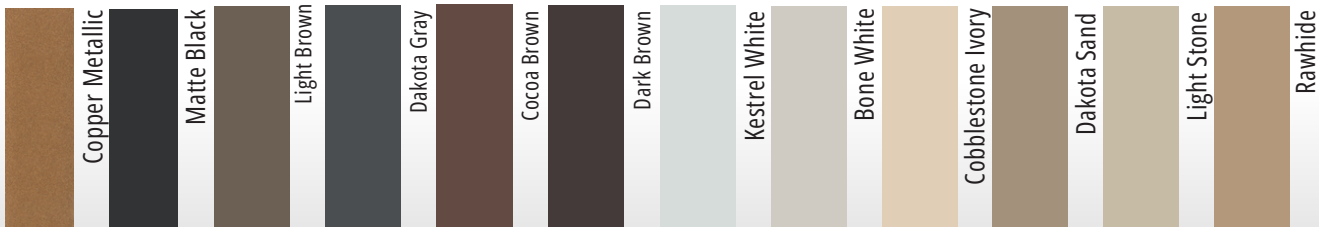
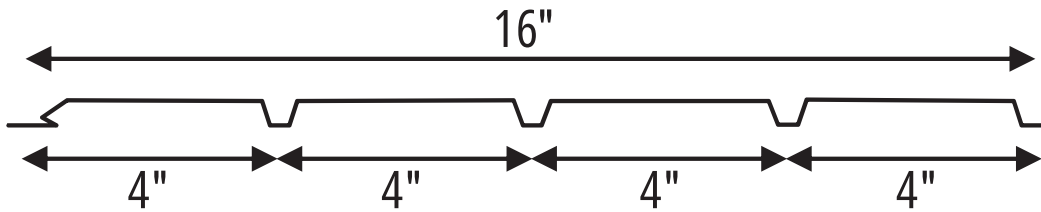

DSResidential Products

ALUMINUM SOFFIT & TRIM COLORS:

KW Kestrel White	CY Clay Mist
BW Bone White	RH Rawhide
CI Cobblestone Ivory	SG Smoke Gray
DS Dakota Sand	RB Roman Blue
LS Light Stone	CR Crimson Red
AG Ash Gray	CO Copper Metallic
CG Charcoal Gray	MK Matte Black**
CB Cocoa Brown	FE Fern Green
LB Light Brown	DG Dakota Gray
DB Dark Brown	
BS Burnished Slate	
GB Gallery Blue	
DB Dark Blue	
BR Barn Red	
CB Classic Burgundy	
FG Forest Green	

STEEL TRIM COLORS:

GA Bare Galvanized	DB Dark Brown
GV Bare Galvalume	BS Burnished Slate
KW Kestrel White	RB Roman Blue
BW Bone White	GB Gallery Blue
CI CobbleStone Ivory	DE Dark Blue
DS Dakota Sand	BR Barn Red
LS Light Stone	CR Crimson Red
RH Rawhide	BY Classic Burgundy
CM Clay Mist	FO Forest Green
AG Ash Gray	FE Fern Green
SG Smoke Gray	BK Black
CG Charcoal Gray	CO Copper Metallic
CB Cocoa Brown	DG Dakota Gray
LB Light Brown	

****Aluminum Fascia only available in these colors**

PARTS LIST

Part Numbers	Description	Standard Lengths	Quantity/Box
DSQSALSO	Solid Soffit	144"	12 Pcs/Carton
DSQSALCV	Center Vent Soffit	23.75"	24 Pcs/Carton

See panel pricing for Soffit prices

1-1/4" Nails

(1 lb Box)

(Limited color availability)

Part Number

Length

DSNA125

1-1/4"



Steel Soffit Panel Strong Rib and Dakota Rib
(36" Panel Coverage)



Part No.

Specify Length

SRXXPE2960

DRXXPE2960



Notes:

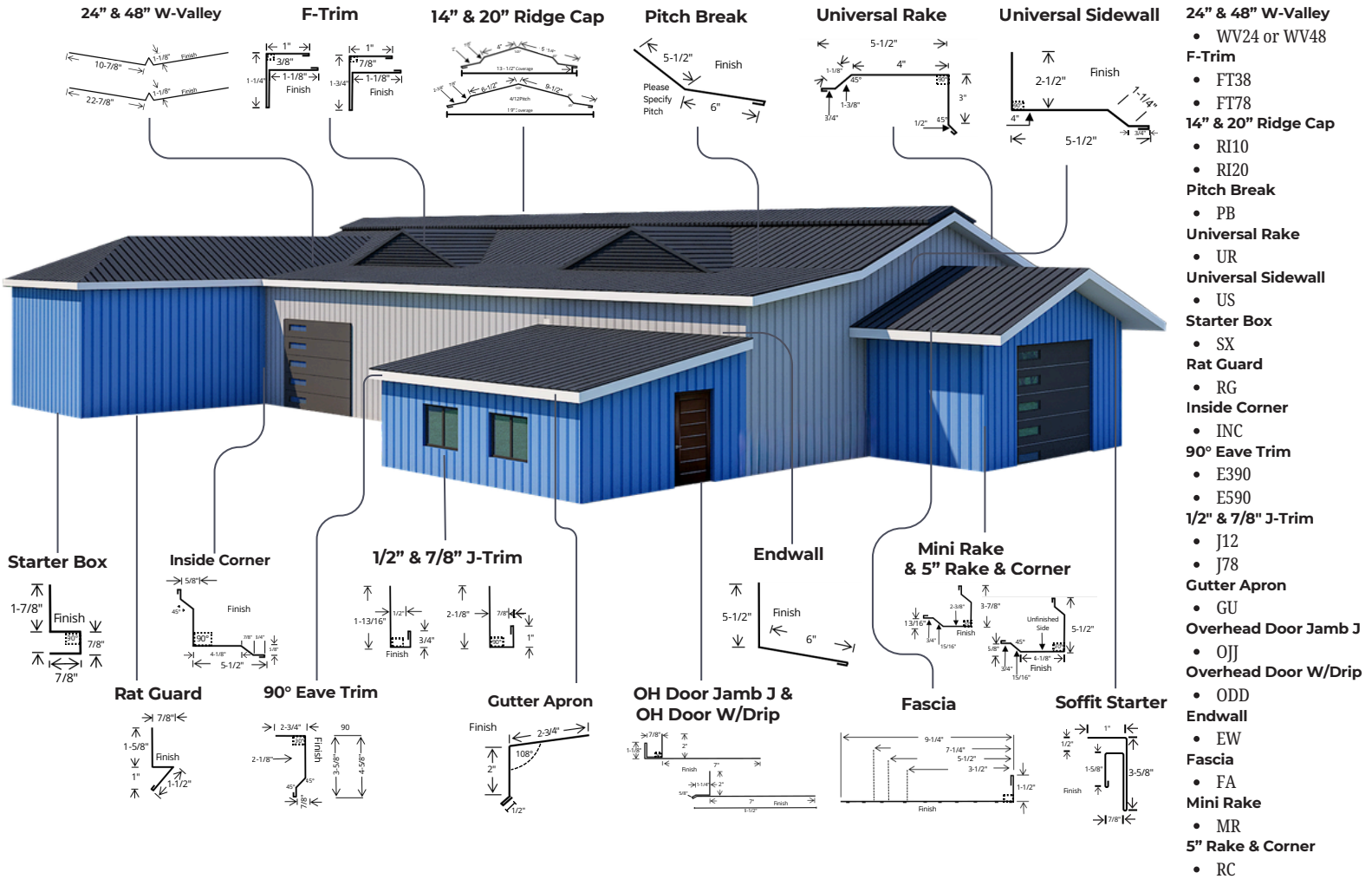

Other Hardware

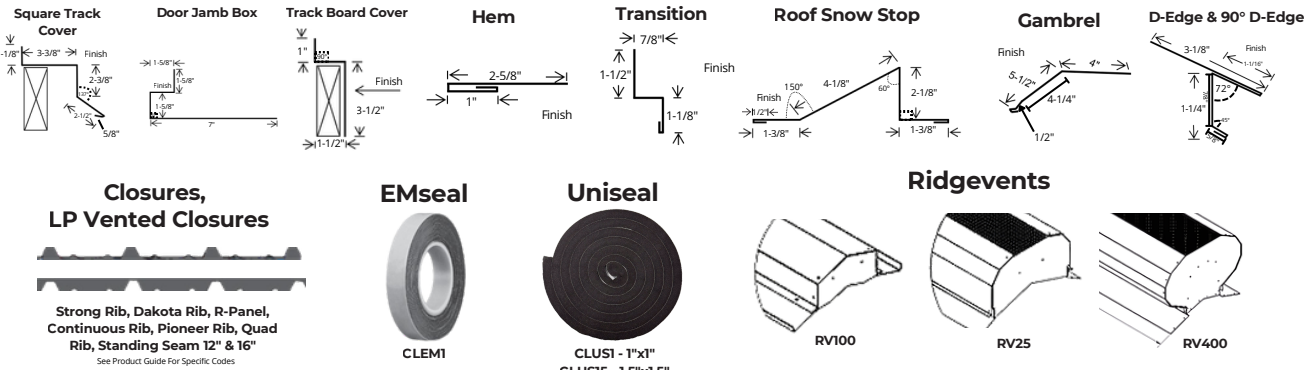



28 Gauge Trims



**Ridge Cap (14" With Stiffening Ribs)
(20" Has Smooth Ribs)**

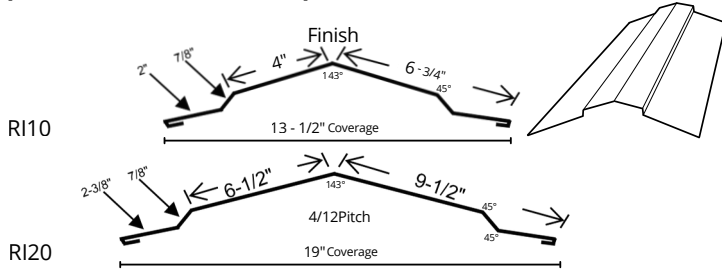

Eave Trim (with Stiffening Ribs)

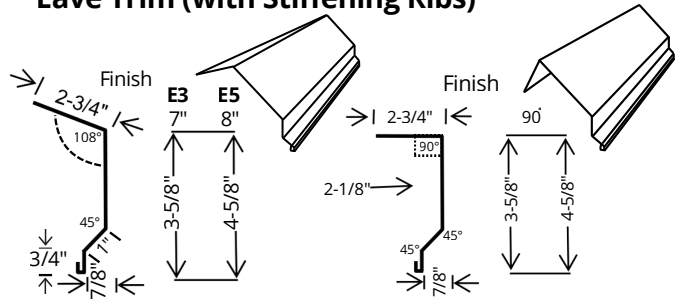

Mini-Rake & Corner (With stiffening ribs)

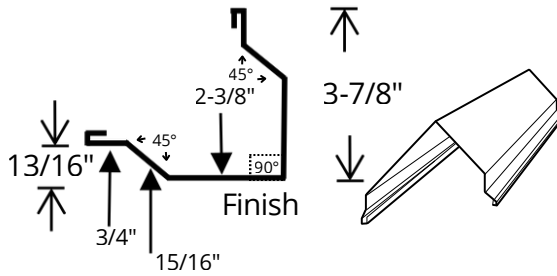

Gutter Apron

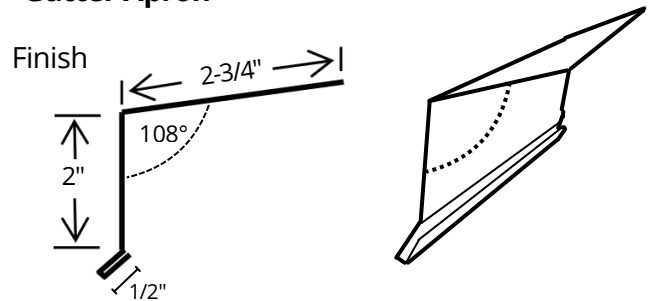

Rake & Corner 5" (With stiffening ribs)

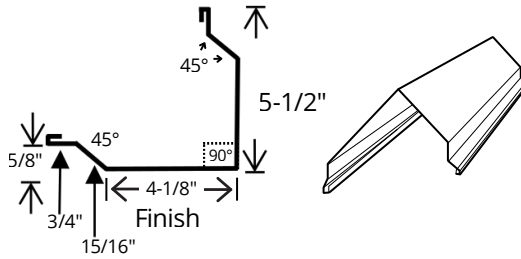

Drip Edge

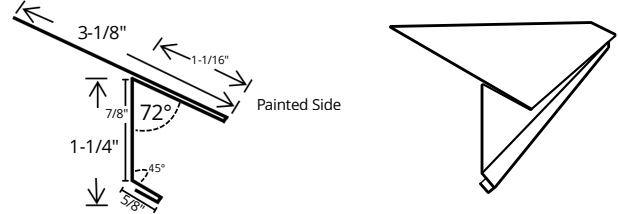

Universal Rake (With stiffening ribs)

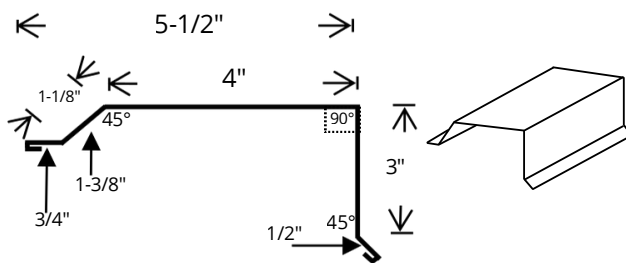

Universal Sidewall (Gable Wall)

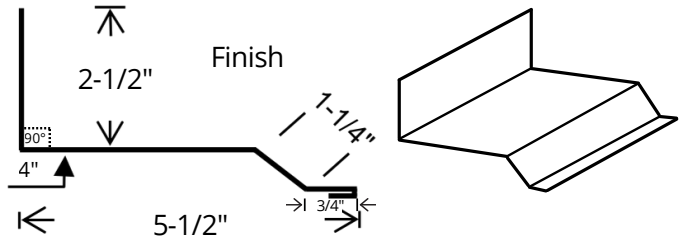

Special Universal Rake

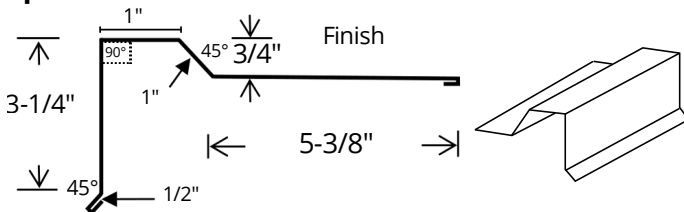

Special Universal Sidewall

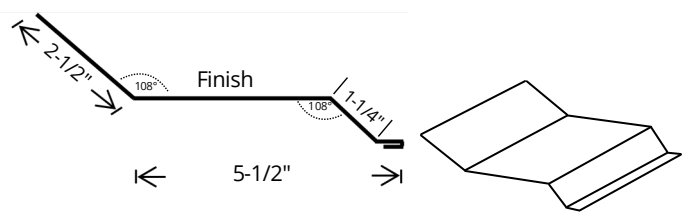

Notes: Copper Metallic & Dark Blue Panels and Trims - add 15%
Notes: Standard Hems are 1/2" - Variable Due to Trim Requirements

Galvanized Trims - Less 10%
Trims offered at 28 Gauge Steel
Upgrade to 26 Gauge Steel

Standard 28 Gauge Trims

<table border="1"> <thead> <tr> <th>Part No.</th> <th>Length</th> <th>Ridge Cap (14" With Stiffening Ribs)</th> </tr> </thead> <tbody> <tr> <td>RI</td> <td>10' 5"</td> <td></td> </tr> <tr> <td>RI20</td> <td>10' 5"</td> <td></td> </tr> <tr> <td>RIDR</td> <td>10' 5"</td> <td></td> </tr> <tr> <td>RI20DR</td> <td>10' 5"</td> <td></td> </tr> </tbody> </table>	Part No.	Length	Ridge Cap (14" With Stiffening Ribs)	RI	10' 5"		RI20	10' 5"		RIDR	10' 5"		RI20DR	10' 5"		<table border="1"> <thead> <tr> <th>Part No.</th> <th>Length</th> <th>Eave Trim (with stiffening ribs)</th> </tr> </thead> <tbody> <tr> <td>E3</td> <td>10' 5"</td> <td></td> </tr> <tr> <td>E390</td> <td>10' 5"</td> <td></td> </tr> <tr> <td>E5</td> <td>10' 5"</td> <td></td> </tr> <tr> <td>E590</td> <td>10' 5"</td> <td></td> </tr> </tbody> </table>	Part No.	Length	Eave Trim (with stiffening ribs)	E3	10' 5"		E390	10' 5"		E5	10' 5"		E590	10' 5"	
Part No.	Length	Ridge Cap (14" With Stiffening Ribs)																													
RI	10' 5"																														
RI20	10' 5"																														
RIDR	10' 5"																														
RI20DR	10' 5"																														
Part No.	Length	Eave Trim (with stiffening ribs)																													
E3	10' 5"																														
E390	10' 5"																														
E5	10' 5"																														
E590	10' 5"																														
<table border="1"> <thead> <tr> <th>Part No.</th> <th>Length</th> <th>Mini-Rake & Corner (With stiffening ribs)</th> </tr> </thead> <tbody> <tr> <td>MR10</td> <td>10' 5"</td> <td></td> </tr> <tr> <td>MR12</td> <td>12' 5"</td> <td></td> </tr> <tr> <td>MR14</td> <td>14' 5"</td> <td></td> </tr> <tr> <td>MR16</td> <td>16' 5"</td> <td></td> </tr> <tr> <td>MR18</td> <td>18' 5"</td> <td></td> </tr> </tbody> </table>	Part No.	Length	Mini-Rake & Corner (With stiffening ribs)	MR10	10' 5"		MR12	12' 5"		MR14	14' 5"		MR16	16' 5"		MR18	18' 5"		<table border="1"> <thead> <tr> <th colspan="2">Gutter Apron</th> </tr> <tr> <th>Part No.</th> <th>Length</th> </tr> </thead> <tbody> <tr> <td>GU</td> <td>10' 5"</td> </tr> </tbody> </table>	Gutter Apron		Part No.	Length	GU	10' 5"						
Part No.	Length	Mini-Rake & Corner (With stiffening ribs)																													
MR10	10' 5"																														
MR12	12' 5"																														
MR14	14' 5"																														
MR16	16' 5"																														
MR18	18' 5"																														
Gutter Apron																															
Part No.	Length																														
GU	10' 5"																														
<table border="1"> <thead> <tr> <th>Part No.</th> <th>Length</th> <th>Rake & Corner (With stiffening ribs)</th> </tr> </thead> <tbody> <tr> <td>RC10</td> <td>10' 5"</td> <td></td> </tr> <tr> <td>RC12</td> <td>12' 5"</td> <td></td> </tr> <tr> <td>RC14</td> <td>14' 5"</td> <td></td> </tr> <tr> <td>RC16</td> <td>16' 5"</td> <td></td> </tr> <tr> <td>RC18</td> <td>18' 5"</td> <td></td> </tr> <tr> <td>RC20</td> <td>20' 5"</td> <td></td> </tr> </tbody> </table>	Part No.	Length	Rake & Corner (With stiffening ribs)	RC10	10' 5"		RC12	12' 5"		RC14	14' 5"		RC16	16' 5"		RC18	18' 5"		RC20	20' 5"		<table border="1"> <thead> <tr> <th colspan="2">D Edge</th> </tr> <tr> <th>Part No.</th> <th>Length</th> </tr> </thead> <tbody> <tr> <td>DE</td> <td>10' 5"</td> </tr> </tbody> </table>	D Edge		Part No.	Length	DE	10' 5"			
Part No.	Length	Rake & Corner (With stiffening ribs)																													
RC10	10' 5"																														
RC12	12' 5"																														
RC14	14' 5"																														
RC16	16' 5"																														
RC18	18' 5"																														
RC20	20' 5"																														
D Edge																															
Part No.	Length																														
DE	10' 5"																														
<table border="1"> <thead> <tr> <th>Part No.</th> <th>Length</th> <th>Universal Rake (With stiffening ribs)</th> </tr> </thead> <tbody> <tr> <td>UR</td> <td>10' 5"</td> <td></td> </tr> </tbody> </table>	Part No.	Length	Universal Rake (With stiffening ribs)	UR	10' 5"		<table border="1"> <thead> <tr> <th colspan="2">Universal Sidewall (Gable Wall)</th> </tr> <tr> <th>Part No.</th> <th>Length</th> </tr> </thead> <tbody> <tr> <td>US</td> <td>10' 5"</td> </tr> </tbody> </table>	Universal Sidewall (Gable Wall)		Part No.	Length	US	10' 5"																		
Part No.	Length	Universal Rake (With stiffening ribs)																													
UR	10' 5"																														
Universal Sidewall (Gable Wall)																															
Part No.	Length																														
US	10' 5"																														
<table border="1"> <thead> <tr> <th colspan="2">Special Universal Rake</th> </tr> <tr> <th>Part No.</th> <th>Length</th> </tr> </thead> <tbody> <tr> <td>SUR</td> <td>10' 5"</td> </tr> </tbody> </table>	Special Universal Rake		Part No.	Length	SUR	10' 5"	<table border="1"> <thead> <tr> <th colspan="2">Special Universal Sidewall</th> </tr> <tr> <th>Part No.</th> <th>Length</th> </tr> </thead> <tbody> <tr> <td>SUS</td> <td>10' 5"</td> </tr> </tbody> </table>	Special Universal Sidewall		Part No.	Length	SUS	10' 5"																		
Special Universal Rake																															
Part No.	Length																														
SUR	10' 5"																														
Special Universal Sidewall																															
Part No.	Length																														
SUS	10' 5"																														

Notes: Copper Metallic & Dark Blue Panels and Trims - add 15%

Galvanized Trims - Less 10%
Trims offered at 28 Gauge Steel
Upgrade to 26 Gauge Steel

Standard 28 Gauge Trims

Endwall (Eave Wall)

Please Specify Pitch

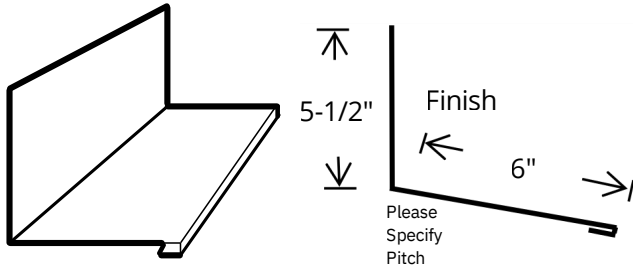

Special Formed Valley

Please Specify Pitch

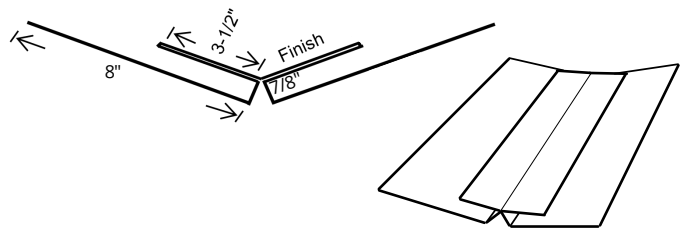

Pitch Break

Please Specify Pitch

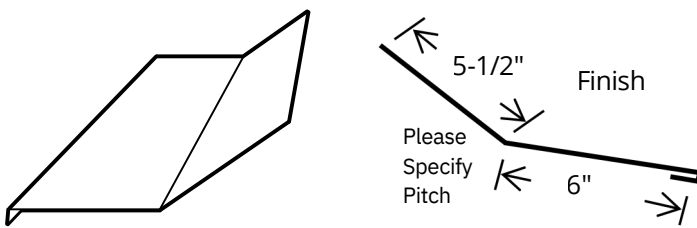

Roof Snow Stop

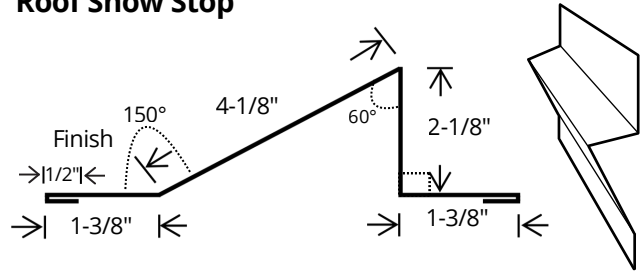

Gambrel

Please Specify Pitch

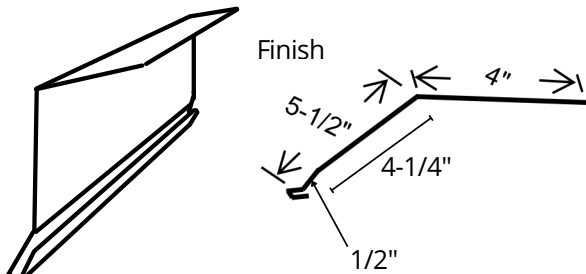

Fascia (With stiffening ribs)

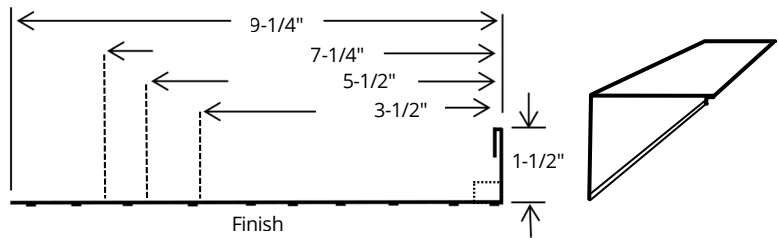

W-Valley

Please Specify Pitch

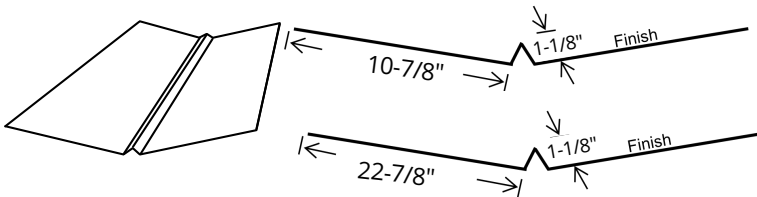

Box End Fascia

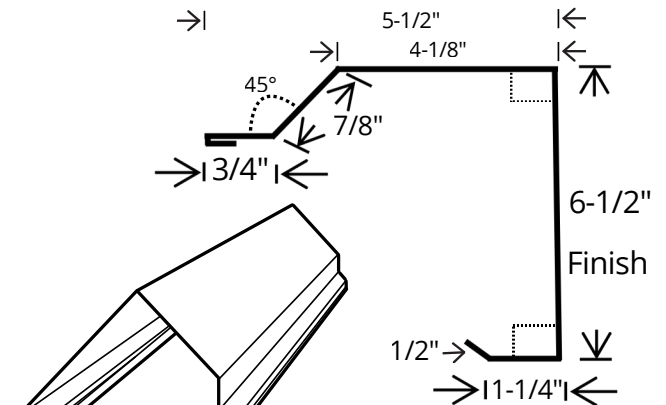

Reverse Ridge & Valley Cap

Please Specify Pitch



Notes: Copper Metallic & Dark Blue Panels and Trims - add 15%
Notes: Standard Hems are 1/2" - Variable Due to Trim Requirements

Galvanized Trims - Less 10%
Trims offered at 28 Gauge Steel
Upgrade to 26 Gauge Steel

Standard 28 Gauge Trims

<p>Endwall (Eave Wall) <i>Please Specify Pitch</i></p> <table border="1"> <thead> <tr> <th>Part No. EW</th> <th>Length</th> </tr> </thead> <tbody> <tr> <td></td> <td>10' 5"</td> </tr> </tbody> </table>	Part No. EW	Length		10' 5"	<p>Special Formed Valley <i>Please Specify Pitch</i></p> <table border="1"> <thead> <tr> <th>Part No. SFV</th> <th>Length</th> </tr> </thead> <tbody> <tr> <td></td> <td>10' 5"</td> </tr> </tbody> </table>	Part No. SFV	Length		10' 5"						
Part No. EW	Length														
	10' 5"														
Part No. SFV	Length														
	10' 5"														
<p>Pitch Break <i>Please Specify Pitch</i></p> <table border="1"> <thead> <tr> <th>Part No. PB</th> <th>Length</th> </tr> </thead> <tbody> <tr> <td></td> <td>10' 5"</td> </tr> </tbody> </table>	Part No. PB	Length		10' 5"	<p>Roof Snow Stop</p> <table border="1"> <thead> <tr> <th>Part No. RSS</th> <th>Length</th> </tr> </thead> <tbody> <tr> <td></td> <td>10' 5"</td> </tr> </tbody> </table>	Part No. RSS	Length		10' 5"						
Part No. PB	Length														
	10' 5"														
Part No. RSS	Length														
	10' 5"														
<p>Gambrel <i>Please Specify Pitch</i></p> <table border="1"> <thead> <tr> <th>Part No. GB</th> <th>Length</th> </tr> </thead> <tbody> <tr> <td></td> <td>10' 5"</td> </tr> </tbody> </table>	Part No. GB	Length		10' 5"	<p>Fascia (With stiffening ribs)</p> <table border="1"> <thead> <tr> <th>Part No.</th> <th>Length</th> </tr> </thead> <tbody> <tr> <td>FA3</td> <td>10' 5"</td> </tr> <tr> <td>FA5</td> <td>10' 5"</td> </tr> <tr> <td>FA7</td> <td>10' 5"</td> </tr> <tr> <td>FA9</td> <td>10' 5"</td> </tr> </tbody> </table>	Part No.	Length	FA3	10' 5"	FA5	10' 5"	FA7	10' 5"	FA9	10' 5"
Part No. GB	Length														
	10' 5"														
Part No.	Length														
FA3	10' 5"														
FA5	10' 5"														
FA7	10' 5"														
FA9	10' 5"														
<p>W-Valley <i>Please Specify Pitch</i></p> <table border="1"> <thead> <tr> <th>Part No.</th> <th>Length</th> </tr> </thead> <tbody> <tr> <td>WV24</td> <td>10' 5"</td> </tr> <tr> <td>WV48</td> <td>10' 5"</td> </tr> </tbody> </table>	Part No.	Length	WV24	10' 5"	WV48	10' 5"	<p>Box End Fascia</p> <table border="1"> <thead> <tr> <th>Part No. BF</th> <th>Length</th> </tr> </thead> <tbody> <tr> <td></td> <td>10' 5"</td> </tr> </tbody> </table>	Part No. BF	Length		10' 5"				
Part No.	Length														
WV24	10' 5"														
WV48	10' 5"														
Part No. BF	Length														
	10' 5"														
<p>Reverse Ridge & Valley Cap <i>Please Specify Pitch</i></p> <table border="1"> <thead> <tr> <th>Part No. RRI</th> <th>Length</th> </tr> </thead> <tbody> <tr> <td></td> <td>10' 5"</td> </tr> </tbody> </table>	Part No. RRI	Length		10' 5"											
Part No. RRI	Length														
	10' 5"														

Notes: Copper Metallic & Dark Blue Panels and Trims - add 15%

Galvanized Trims - Less 10%
Trims offered at 28 Gauge Steel
Upgrade to 26 Gauge Steel

Standard 28 Gauge Trims

F-Trim

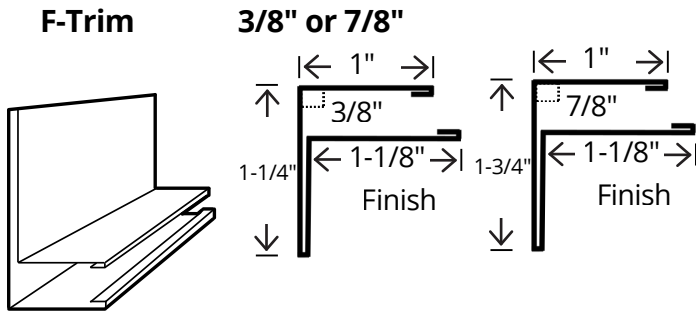

Hems are < 1/2"

J Trim

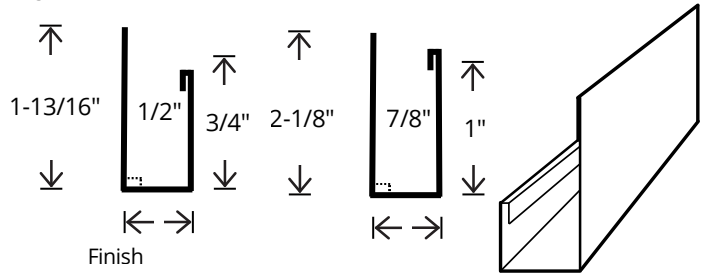

**3/8" or 7/8" Soffit Divider
(Mitre Divider Moulding)**

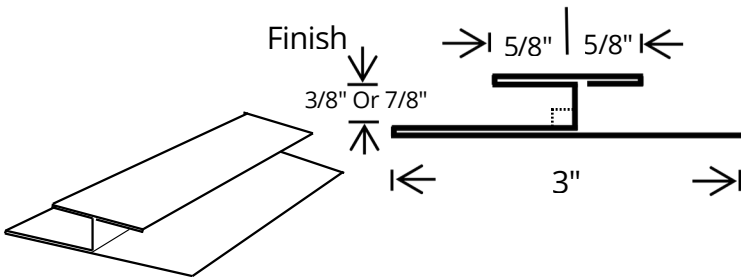

Double J Trim

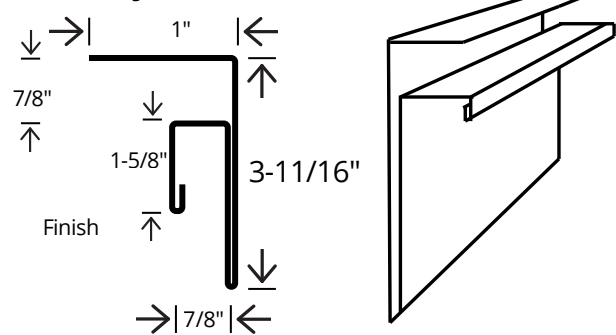

Soffit Starter

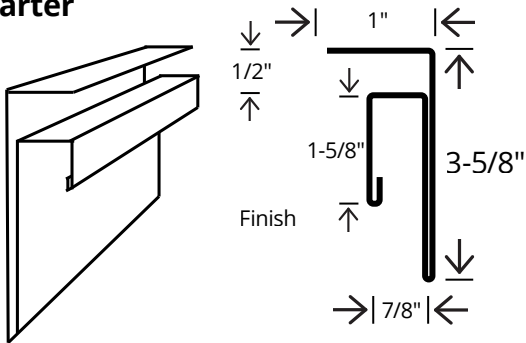

Base Mouldings

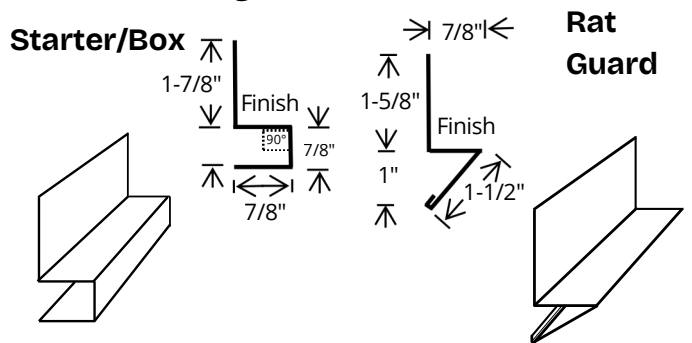

Boxed Soffit Trim

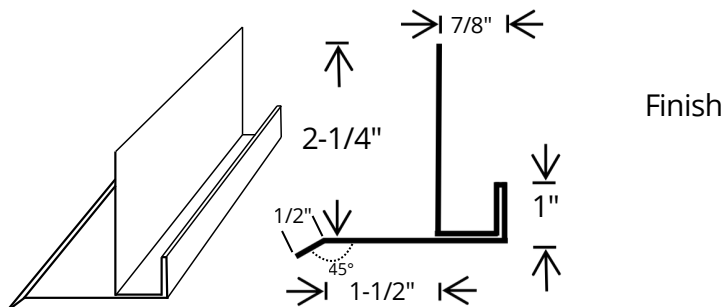

Transition - 7/8"

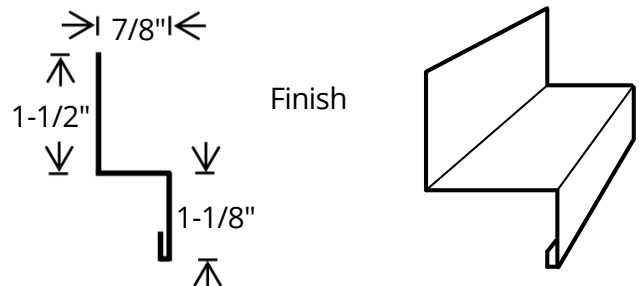

Notes: Copper Metallic & Dark Blue Panels and Trims - add 15%
Notes: Standard Hems are 1/2" - Variable Due to Trim Requirements

Galvanized Trims - Less 10%
Trims offered at 28 Gauge Steel
Upgrade to 26 Gauge Steel

Standard 28 Gauge Trims

<p>F-Trim 3/8" or 7/8"</p> <table border="1"> <thead> <tr> <th>Part No.</th> <th>Length</th> </tr> </thead> <tbody> <tr> <td>FT38</td> <td>10' 5"</td> </tr> <tr> <td>FT78</td> <td>10' 5"</td> </tr> </tbody> </table>	Part No.	Length	FT38	10' 5"	FT78	10' 5"	<p>J Trim</p> <table border="1"> <thead> <tr> <th>Part No.</th> <th>Length</th> </tr> </thead> <tbody> <tr> <td>J12 (1/2")</td> <td>10' 5"</td> </tr> <tr> <td>J7810</td> <td>10' 5"</td> </tr> <tr> <td>J7812</td> <td>12' 5"</td> </tr> </tbody> </table>	Part No.	Length	J12 (1/2")	10' 5"	J7810	10' 5"	J7812	12' 5"
Part No.	Length														
FT38	10' 5"														
FT78	10' 5"														
Part No.	Length														
J12 (1/2")	10' 5"														
J7810	10' 5"														
J7812	12' 5"														
<p>3/8" or 7/8" Soffit Divider (Mitre Divider Moulding)</p> <table border="1"> <thead> <tr> <th>Part No.</th> <th>Length</th> </tr> </thead> <tbody> <tr> <td>SOFD78</td> <td>10' 5"</td> </tr> <tr> <td>SOFD38</td> <td>10' 5"</td> </tr> </tbody> </table>	Part No.	Length	SOFD78	10' 5"	SOFD38	10' 5"	<p>Double J Trim</p> <table border="1"> <thead> <tr> <th>Part No.</th> <th>Length</th> </tr> </thead> <tbody> <tr> <td>DJ78</td> <td>10' 5"</td> </tr> <tr> <td>DJ12</td> <td>10' 5"</td> </tr> </tbody> </table>	Part No.	Length	DJ78	10' 5"	DJ12	10' 5"		
Part No.	Length														
SOFD78	10' 5"														
SOFD38	10' 5"														
Part No.	Length														
DJ78	10' 5"														
DJ12	10' 5"														
<p>Soffit Starter</p> <table border="1"> <thead> <tr> <th>Part No.</th> <th>Length</th> </tr> </thead> <tbody> <tr> <td>SOFS</td> <td>10' 5"</td> </tr> </tbody> </table>	Part No.	Length	SOFS	10' 5"	<p>Base Mouldings</p> <table border="1"> <thead> <tr> <th>Part No.</th> <th>Length</th> </tr> </thead> <tbody> <tr> <td>SX</td> <td>10' 5"</td> </tr> <tr> <td>RG</td> <td>10' 5"</td> </tr> </tbody> </table>	Part No.	Length	SX	10' 5"	RG	10' 5"				
Part No.	Length														
SOFS	10' 5"														
Part No.	Length														
SX	10' 5"														
RG	10' 5"														
<p>Boxed Soffit Trim</p> <table border="1"> <thead> <tr> <th>Part No.</th> <th>Length</th> </tr> </thead> <tbody> <tr> <td>BOXSOF</td> <td>10' 5"</td> </tr> </tbody> </table>	Part No.	Length	BOXSOF	10' 5"	<p>Transition - 7/8"</p> <table border="1"> <thead> <tr> <th>Part No.</th> <th>Length</th> </tr> </thead> <tbody> <tr> <td>TR78</td> <td>10' 5"</td> </tr> </tbody> </table>	Part No.	Length	TR78	10' 5"						
Part No.	Length														
BOXSOF	10' 5"														
Part No.	Length														
TR78	10' 5"														

Notes: Copper Metallic & Dark Blue Panels and Trims - add 15%

Galvanized Trims - Less 10%
Trims offered at 28 Gauge Steel
Upgrade to 26 Gauge Steel

Standard 28 Gauge Trims

Hem Trim

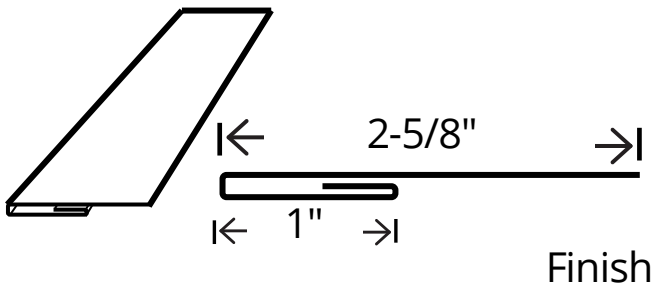

Angle Flashing

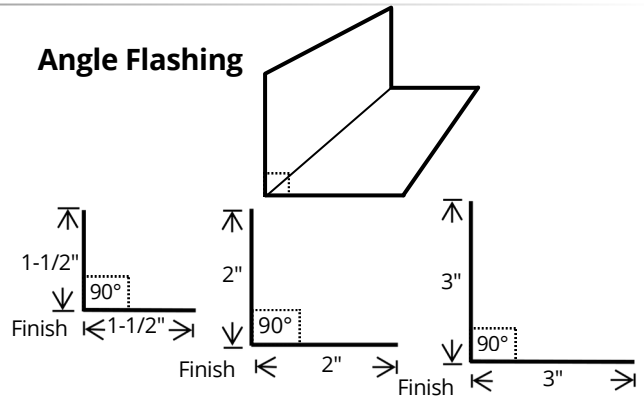

Brick Mould Trim

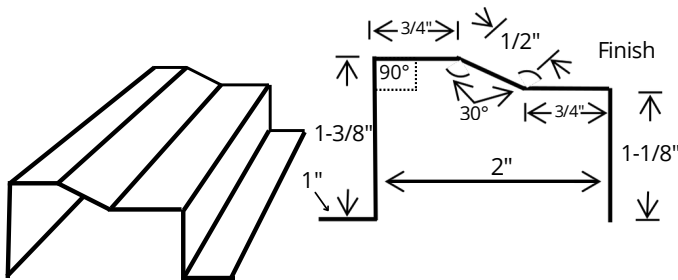

Inside Corner

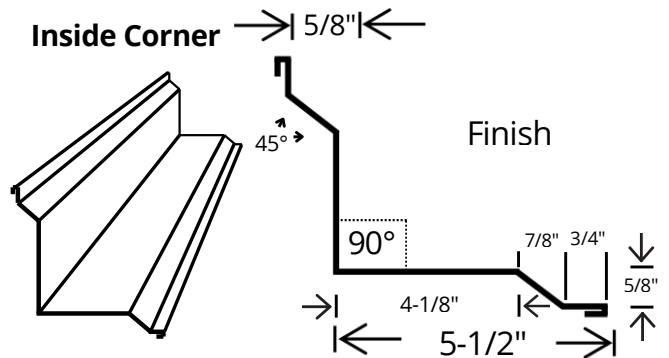

Wall & Ceiling Trim

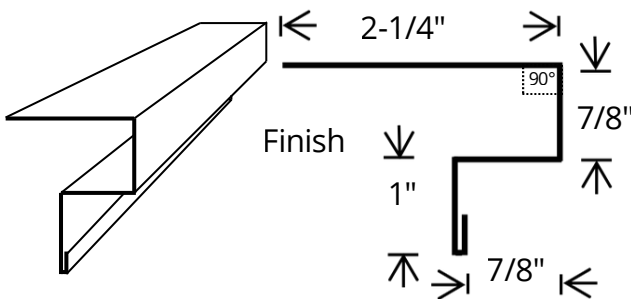

Square Track Cover

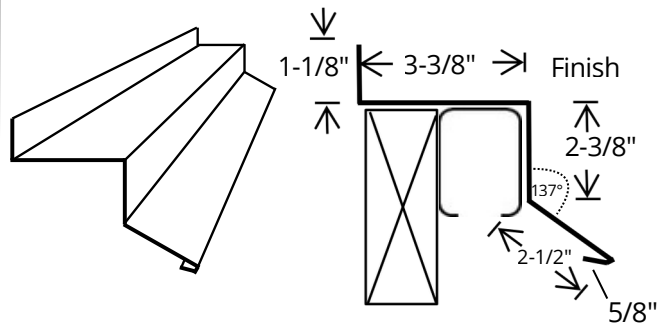

Drip Cap

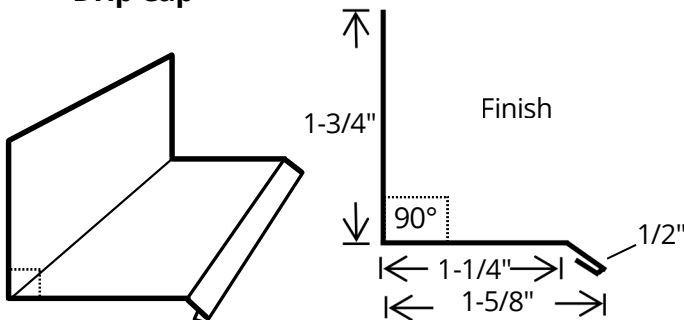

Notes: Copper Metallic & Dark Blue Panels and Trims - add 15%
 Notes: Standard Hems are 1/2" - Variable Due to Trim Requirements

Galvanized Trims - Less 10%
 Trims offered at 28 Gauge Steel
 Upgrade to 26 Gauge Steel

Standard 28 Gauge Trims



<p>Hem Trim</p> <table border="1"> <thead> <tr> <th>Part No.</th> <th>Length</th> </tr> </thead> <tbody> <tr> <td>HT</td> <td>10' 5"</td> </tr> </tbody> </table>	Part No.	Length	HT	10' 5"	<p>Angle Flashing</p> <table border="1"> <thead> <tr> <th>Part No.</th> <th>Length</th> </tr> </thead> <tbody> <tr> <td>AF15</td> <td>10' 5"</td> </tr> <tr> <td>AF2</td> <td>10' 5"</td> </tr> <tr> <td>AF3</td> <td>10' 5"</td> </tr> </tbody> </table>	Part No.	Length	AF15	10' 5"	AF2	10' 5"	AF3	10' 5"
Part No.	Length												
HT	10' 5"												
Part No.	Length												
AF15	10' 5"												
AF2	10' 5"												
AF3	10' 5"												
<p>Brick Mould Trim</p> <table border="1"> <thead> <tr> <th>Part No.</th> <th>Length</th> </tr> </thead> <tbody> <tr> <td>BM</td> <td>10' 5"</td> </tr> </tbody> </table>	Part No.	Length	BM	10' 5"	<p>Inside Corner</p> <table border="1"> <thead> <tr> <th>Part No.</th> <th>Length</th> </tr> </thead> <tbody> <tr> <td>INC</td> <td>10' 5"</td> </tr> </tbody> </table>	Part No.	Length	INC	10' 5"				
Part No.	Length												
BM	10' 5"												
Part No.	Length												
INC	10' 5"												
<p>Wall & Ceiling Trim</p> <table border="1"> <thead> <tr> <th>Part No.</th> <th>Length</th> </tr> </thead> <tbody> <tr> <td>WC</td> <td>10' 5"</td> </tr> </tbody> </table>	Part No.	Length	WC	10' 5"	<p>Square Track Cover</p> <table border="1"> <thead> <tr> <th>Part No.</th> <th>Length</th> </tr> </thead> <tbody> <tr> <td>STC</td> <td>10' 5"</td> </tr> </tbody> </table>	Part No.	Length	STC	10' 5"				
Part No.	Length												
WC	10' 5"												
Part No.	Length												
STC	10' 5"												
<p>Drip Cap</p> <table border="1"> <thead> <tr> <th>Part No.</th> <th>Length</th> </tr> </thead> <tbody> <tr> <td>DC</td> <td>10' 5"</td> </tr> </tbody> </table>	Part No.	Length	DC	10' 5"									
Part No.	Length												
DC	10' 5"												

Notes: Copper Metallic & Dark Blue Panels and Trims - add 15%
 Notes: Standard Hems are 1/2" - Variable Due to Trim Requirements

Galvanized Trims - Less 10%
 Trims offered at 28 Gauge Steel
 Upgrade to 26 Gauge Steel

Standard 28 Gauge Trims

Track Board Cover

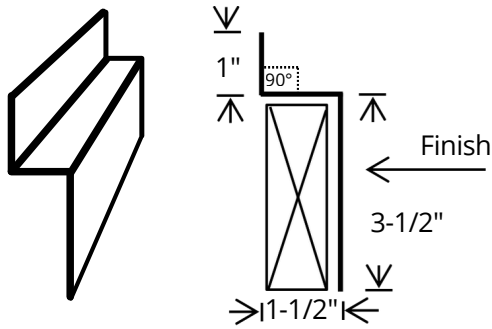

7" OH Door Jamb J

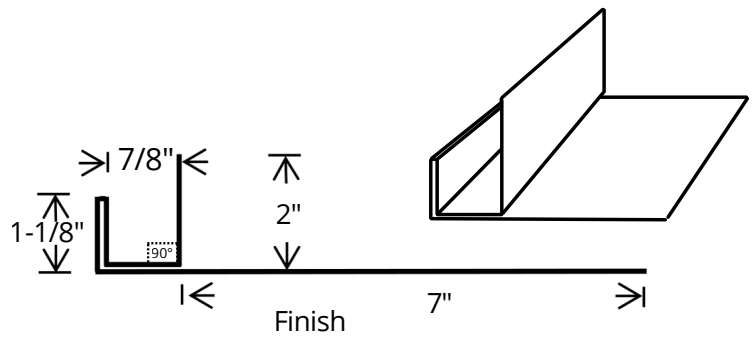

Special Track Cover

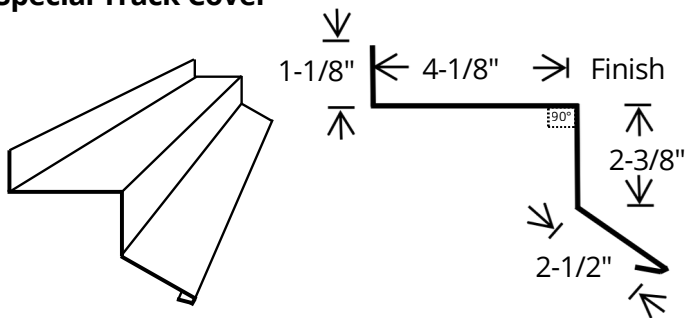

7" OH Door w/Drip

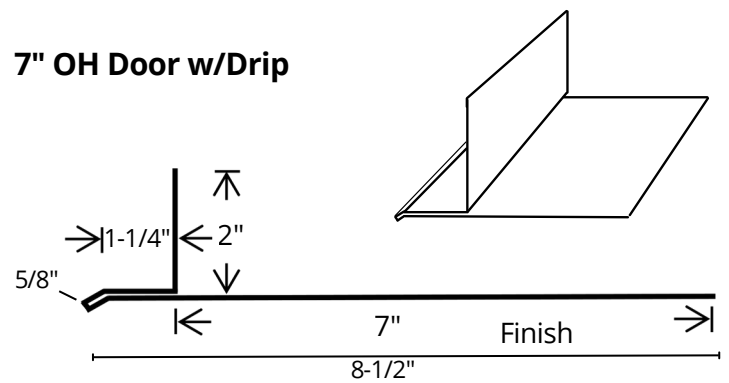

7" Door Jamb Box

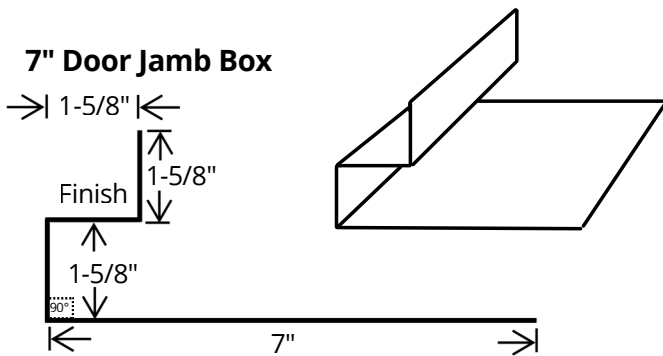

9" OH Door Jamb J

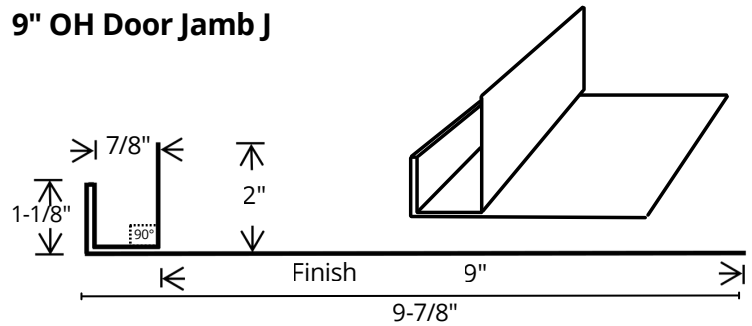

9" Door Jamb Box

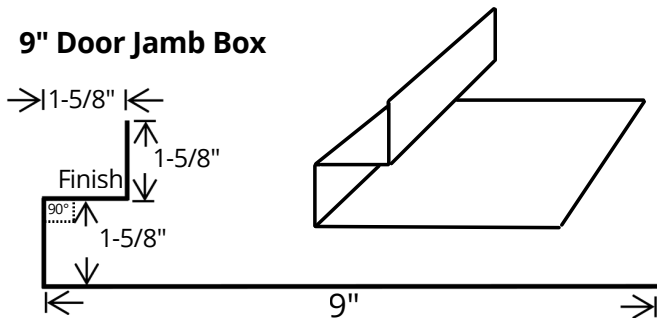

9" OH Door w/Drip

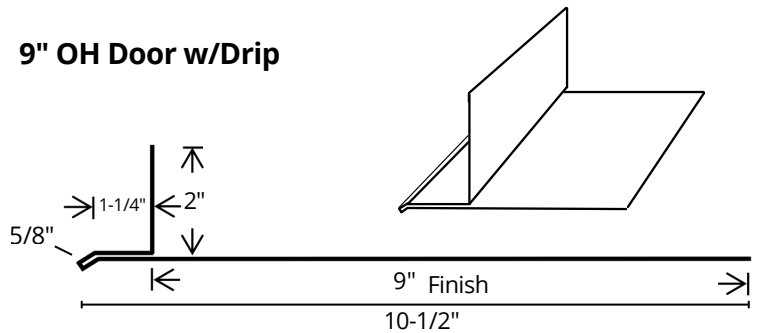

Notes: Copper Metallic & Dark Blue Panels and Trims - add 15%
 Notes: Standard Hems are 1/2" - Variable Due to Trim Requirements

Galvanized Trims - Less 10%
 Trims offered at 28 Gauge Steel
 Upgrade to 26 Gauge Steel

Standard 28 Gauge Trims

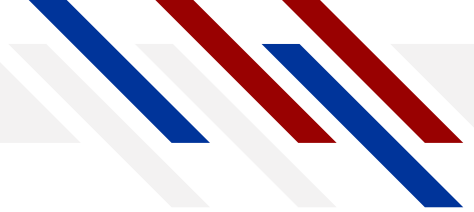

<p>Track Board Cover</p> <table border="1"> <thead> <tr> <th>Part No.</th> <th>Length</th> </tr> </thead> <tbody> <tr> <td>TBC</td> <td>10' 5"</td> </tr> </tbody> </table>	Part No.	Length	TBC	10' 5"	<p>7" OH Door Jamb J</p> <table border="1"> <thead> <tr> <th>Part No.</th> <th>Length</th> </tr> </thead> <tbody> <tr> <td>OJJ7</td> <td>10' 5"</td> </tr> <tr> <td>OJJ7</td> <td>12' 6"</td> </tr> <tr> <td>OJJ7</td> <td>14' 5"</td> </tr> <tr> <td>OJJ7</td> <td>16' 5"</td> </tr> <tr> <td>OJJ7</td> <td>18' 5"</td> </tr> </tbody> </table>	Part No.	Length	OJJ7	10' 5"	OJJ7	12' 6"	OJJ7	14' 5"	OJJ7	16' 5"	OJJ7	18' 5"								
Part No.	Length																								
TBC	10' 5"																								
Part No.	Length																								
OJJ7	10' 5"																								
OJJ7	12' 6"																								
OJJ7	14' 5"																								
OJJ7	16' 5"																								
OJJ7	18' 5"																								
<p>Special Track Cover</p> <table border="1"> <thead> <tr> <th>Part No.</th> <th>Length</th> </tr> </thead> <tbody> <tr> <td>SPC</td> <td>10' 5"</td> </tr> </tbody> </table>	Part No.	Length	SPC	10' 5"	<p>7" OH Door w/Drip</p> <table border="1"> <thead> <tr> <th>Part No.</th> <th>Length</th> </tr> </thead> <tbody> <tr> <td>ODD7</td> <td>10' 5"</td> </tr> <tr> <td>ODD7</td> <td>12' 5"</td> </tr> <tr> <td>ODD7</td> <td>14' 5"</td> </tr> <tr> <td>ODD7</td> <td>16' 5"</td> </tr> <tr> <td>ODD7</td> <td>18' 5"</td> </tr> </tbody> </table>	Part No.	Length	ODD7	10' 5"	ODD7	12' 5"	ODD7	14' 5"	ODD7	16' 5"	ODD7	18' 5"								
Part No.	Length																								
SPC	10' 5"																								
Part No.	Length																								
ODD7	10' 5"																								
ODD7	12' 5"																								
ODD7	14' 5"																								
ODD7	16' 5"																								
ODD7	18' 5"																								
<p>7" Door Jamb Box</p> <table border="1"> <thead> <tr> <th>Part No.</th> <th>Length</th> </tr> </thead> <tbody> <tr> <td>DJB7</td> <td>10' 5"</td> </tr> <tr> <td>DJB7</td> <td>12' 5"</td> </tr> <tr> <td>DJB7</td> <td>14' 5"</td> </tr> <tr> <td>DJB7</td> <td>16' 5"</td> </tr> <tr> <td>DJB7</td> <td>18' 5"</td> </tr> </tbody> </table>	Part No.	Length	DJB7	10' 5"	DJB7	12' 5"	DJB7	14' 5"	DJB7	16' 5"	DJB7	18' 5"	<p>9" OH Door Jamb J</p> <table border="1"> <thead> <tr> <th>Part No.</th> <th>Length</th> </tr> </thead> <tbody> <tr> <td>OJJ9</td> <td>10' 5"</td> </tr> <tr> <td>OJJ9</td> <td>12' 5"</td> </tr> <tr> <td>OJJ9</td> <td>14' 5"</td> </tr> <tr> <td>OJJ9</td> <td>16' 5"</td> </tr> <tr> <td>OJJ9</td> <td>18' 5"</td> </tr> </tbody> </table>	Part No.	Length	OJJ9	10' 5"	OJJ9	12' 5"	OJJ9	14' 5"	OJJ9	16' 5"	OJJ9	18' 5"
Part No.	Length																								
DJB7	10' 5"																								
DJB7	12' 5"																								
DJB7	14' 5"																								
DJB7	16' 5"																								
DJB7	18' 5"																								
Part No.	Length																								
OJJ9	10' 5"																								
OJJ9	12' 5"																								
OJJ9	14' 5"																								
OJJ9	16' 5"																								
OJJ9	18' 5"																								
<p>9" Door Jamb Box</p> <table border="1"> <thead> <tr> <th>Part No.</th> <th>Length</th> </tr> </thead> <tbody> <tr> <td>DJB9</td> <td>10' 5"</td> </tr> <tr> <td>DJB9</td> <td>12' 5"</td> </tr> <tr> <td>DJB9</td> <td>14' 5"</td> </tr> <tr> <td>DJB9</td> <td>16' 5"</td> </tr> <tr> <td>DJB9</td> <td>18' 5"</td> </tr> </tbody> </table>	Part No.	Length	DJB9	10' 5"	DJB9	12' 5"	DJB9	14' 5"	DJB9	16' 5"	DJB9	18' 5"	<p>9" OH Door w/Drip</p> <table border="1"> <thead> <tr> <th>Part No.</th> <th>Length</th> </tr> </thead> <tbody> <tr> <td>ODD9</td> <td>10' 5"</td> </tr> <tr> <td>ODD9</td> <td>12' 5"</td> </tr> <tr> <td>ODD9</td> <td>14' 5"</td> </tr> <tr> <td>ODD9</td> <td>16' 5"</td> </tr> <tr> <td>ODD9</td> <td>18' 5"</td> </tr> </tbody> </table>	Part No.	Length	ODD9	10' 5"	ODD9	12' 5"	ODD9	14' 5"	ODD9	16' 5"	ODD9	18' 5"
Part No.	Length																								
DJB9	10' 5"																								
DJB9	12' 5"																								
DJB9	14' 5"																								
DJB9	16' 5"																								
DJB9	18' 5"																								
Part No.	Length																								
ODD9	10' 5"																								
ODD9	12' 5"																								
ODD9	14' 5"																								
ODD9	16' 5"																								
ODD9	18' 5"																								

Standard 28 Gauge Trims

3-1/2" Door Jamb

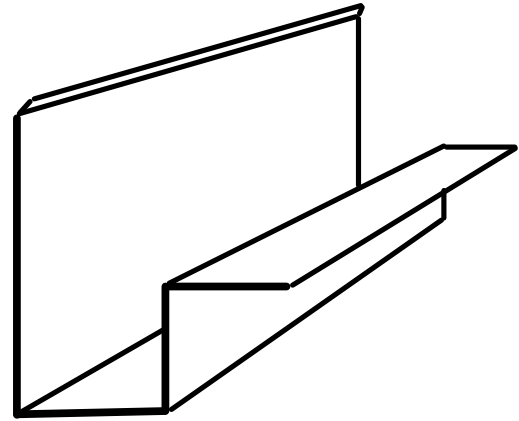
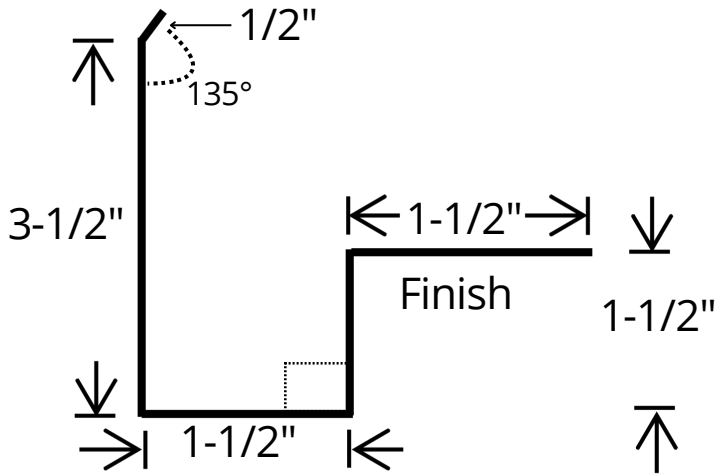

Counter Flashing

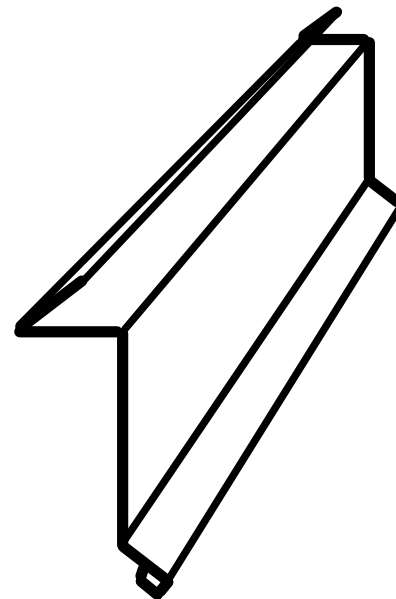
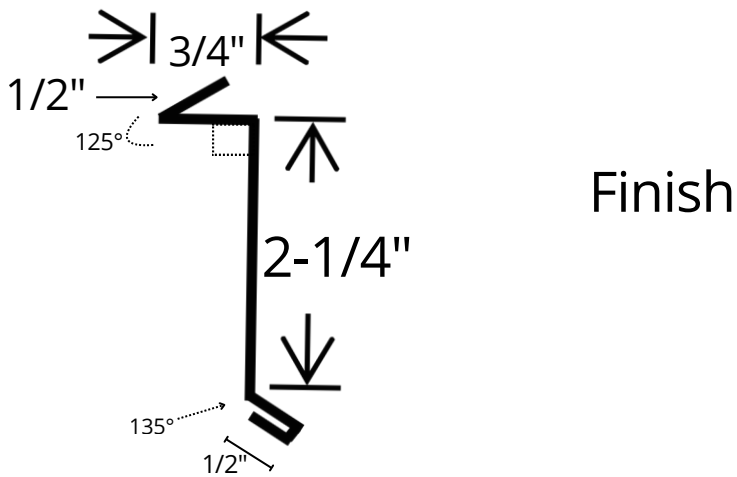

Notes: Copper Metallic & Dark Blue Panels and Trims - add 15%
 Notes: Standard Hems are 1/2" - Variable Due to Trim Requirements

Galvanized Trims - Less 10%
 Trims offered at 28 Gauge Steel
 Upgrade to 26 Gauge Steel

Standard 28 Gauge Trims

3-1/2" Door Jamb

Part No.	Length
DJ3	10' 5"
DJ3	12' 5"
DJ3	14' 5"
DJ3	16' 5"
DJ3	18' 5"

Counter Flashing

Part No.	Length
CF	10' 5"

Commercial Soffit

Commercial Soffit (Solid or Vented White)

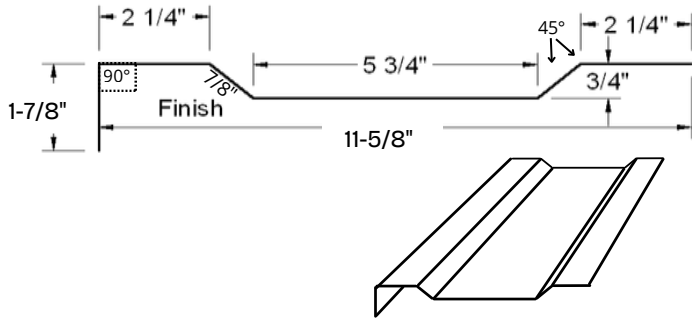

Part No.	Length
COMSOFFIT	12' 3"

Vented ONLY in white / Solid all colors
 1-7/8" x 2-1/4" x 5-3/4" x 2-1/4" (1/4" Holes)
 *** Air Flow: 1/4" HOLES - 26.3 square inches / LF

Curtain Trim

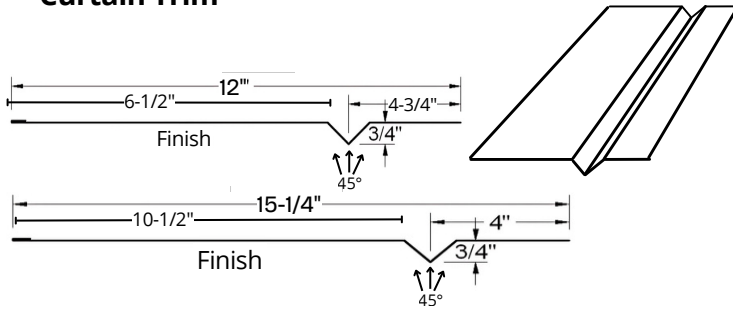

Part No.	Length
CURTAINTRI212	12' 3"
CURTAINTRI1512	12' 3"

Soffit Trim

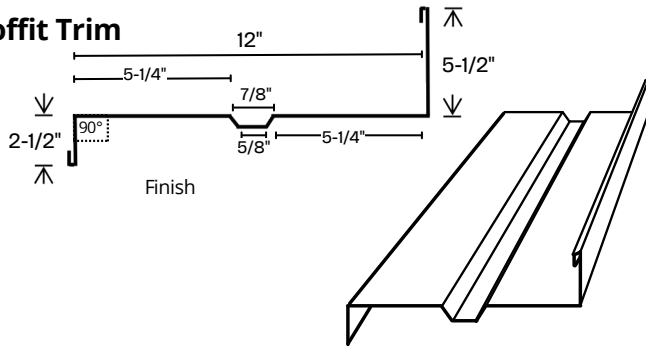

Part No.	Length
SOFT	10' 5"

Soffit Snow Guard

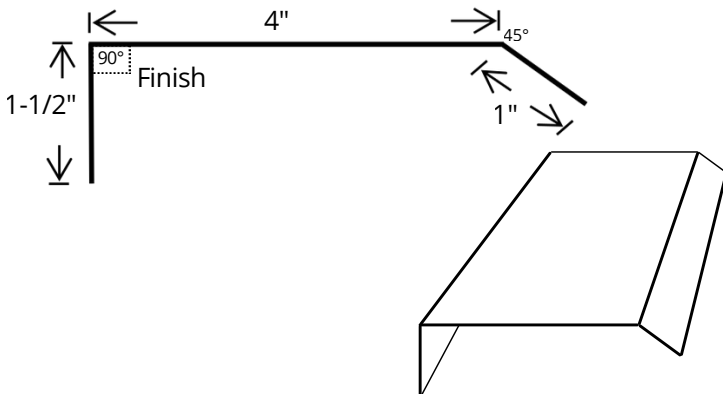

Part No.	Length
SOFG	12' 3"

Notes: Copper Metallic & Dark Blue Panels and Trims - add 15%
 Notes: Standard Hems are 1/2" - Variable Due to Trim Requirements

Galvanized Trims - Less 10%
 Trims offered at 28 Gauge Steel
 Upgrade to 26 Gauge Steel



Standing Seam Trims



Standing Seam Trims

** Each trim line item must indicate closed hem or open hem, which will depend on placement.

IF EXPOSED -THEN CLOSED HEMS

IF HIDDEN -THEN OPEN HEMS

Please indicate whether Trim Installation is HIDDEN fastener system or EXPOSED fastener system.

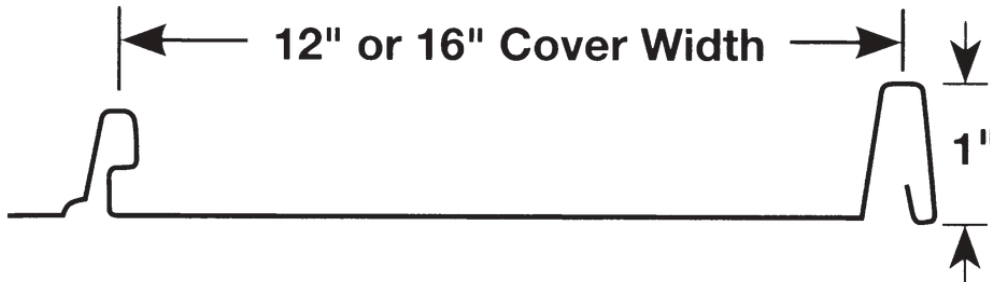

SS Ridge Cap (Hip/Ridge)

Part No.	Length
SSRI	10' 5"

Reverse Ridge & Valley Cap

Part No.	Length
RRI	10' 5"

Ridge Cap

14" Ridge has Stiffening Ribs

Part No.	Length
RI	10' 5"
RI20	10' 5"

**If Open Hems -No stiffening ribs

SS Rake Trim

Part No.	Length
SSRT	10' 5"

SS Pitch Break

Part No.	Length
SSPB	10' 5"

SS Rake Cleat

RakeCleat is to be used only with SS Rake Trim (SSRT)

Part No.	Length
SSRC	10' 5"

W Valley

Please Specify Pitch

Part No.	Length
WV24	10' 5"
WV48	10' 5"

Mini Universal Rake

Must use SS Cleat (SSCL) if Open Hem/Hidden Fastener

Part No.	Length
MUR	10' 5"

Standing Seam Trims

** Each trim line item must indicate closed hem or open hem, which will depend on placement.

IF EXPOSED - THEN CLOSED HEMS

IF HIDDEN - THEN OPEN HEMS

Please indicate whether Trim Installation is HIDDEN fastener system or EXPOSED fastener system.

SS Ridge Cap (Hip/Ridge)

Specify Pitch & Indicate
Open/Closed Hem

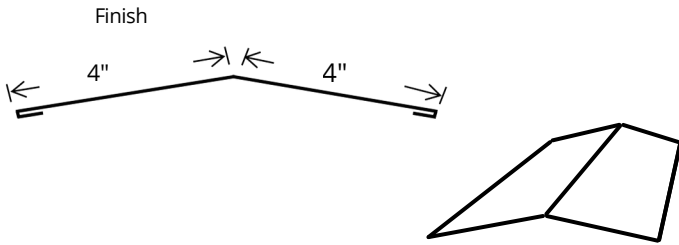

Reverse Ridge & Valley Cap

Specify Pitch & Indicate
Open/Closed Hem

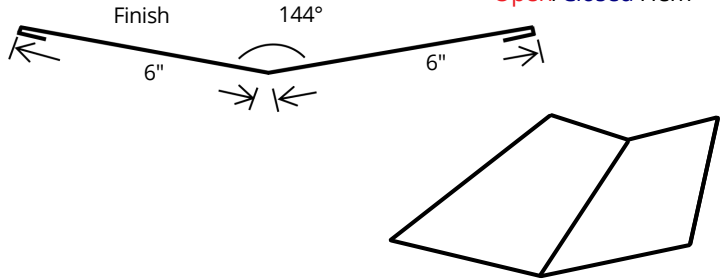

Ridge Cap

14" Ridge has Stiffening Ribs
Closed
Specify Pitch

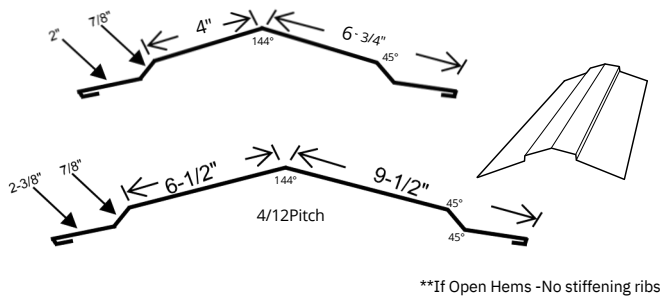

**If Open Hems - No stiffening ribs

SS Rake Trim

Indicate Open/Closed Hem

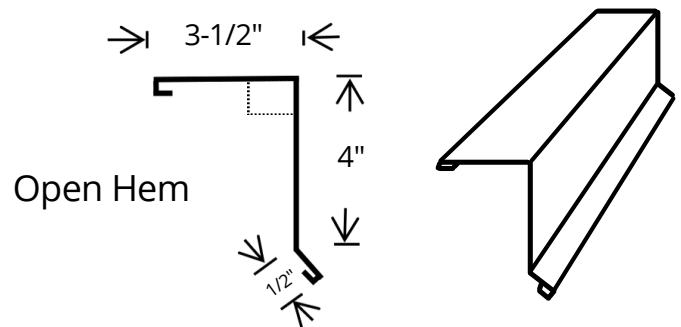

SS Pitch Break

Specify Pitch & Indicate
Open/Closed Hem

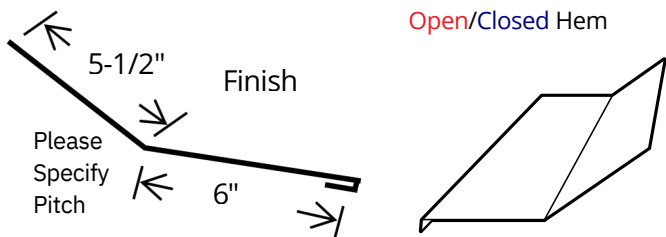

Please Specify Pitch

SS Rake Cleat

Open

RakeCleat is to be used only with SS Rake Trim (SSRT)

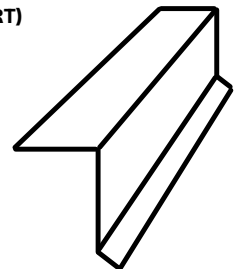
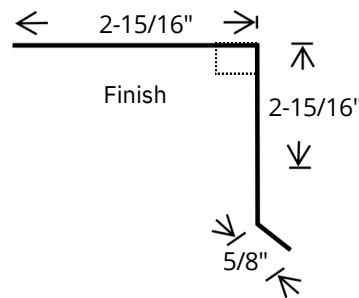

W Valley

Specify Pitch & Indicate Open/Closed Hem

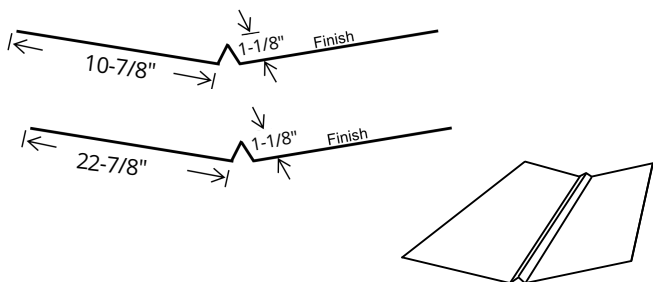

Mini Universal Rake

Indicate Open/Closed
Must use SS Cleat (SSCL) if Open Hem/Hidden Fastener

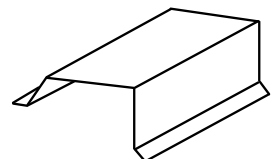
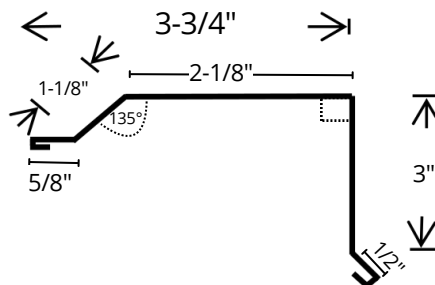

Notes: Copper Metallic & Dark Blue Panels and Trims - add 15%
Notes: Standard Hems are 1/2" - Variable Due to Trim Requirements

Galvanized Trims - Less 10%
Trims offered at 28 Gauge Steel
Upgrade to 26 Gauge Steel

Standing Seam Trims

Must use SS Cleat (SSCL) if Open Hem/Hidden Fastener

SS Universal Rake (Smooth) Indicate Open/Closed

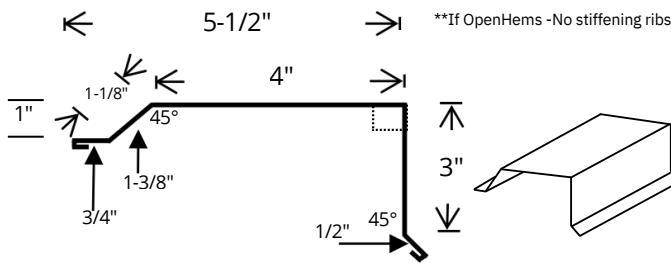

Universal Sidewall

Open

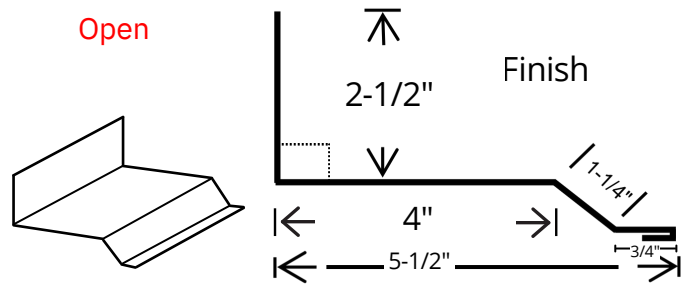

Must use SS Cleat (SSCL) if Open Hem/Hidden Fastener

Special Universal Rake Indicate Open/Closed

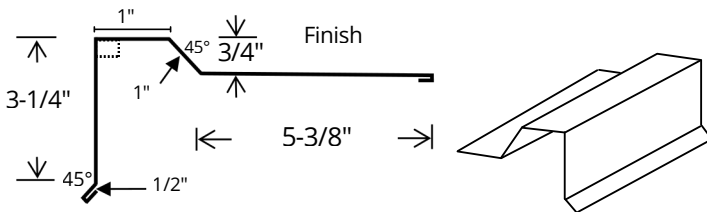

SS Endwall Specify Pitch Open Hem

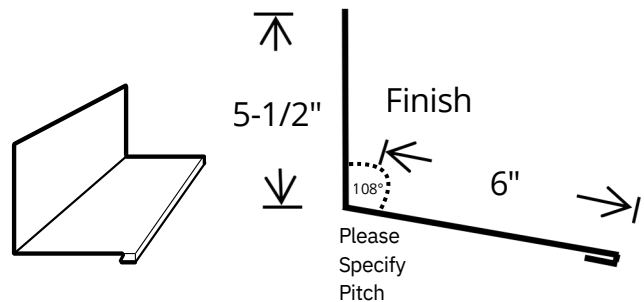

Gutter Apron

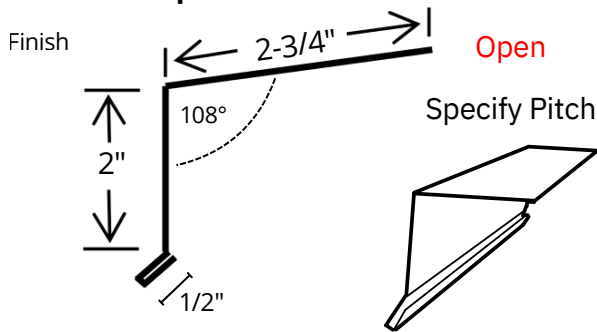

SS Z Closure

Open

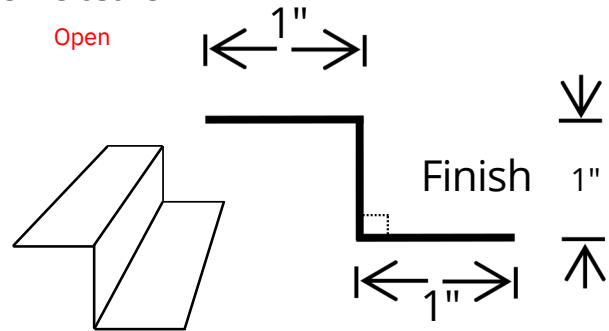

SS D Edge

Specify Pitch & Indicate

Open/Closed Hem

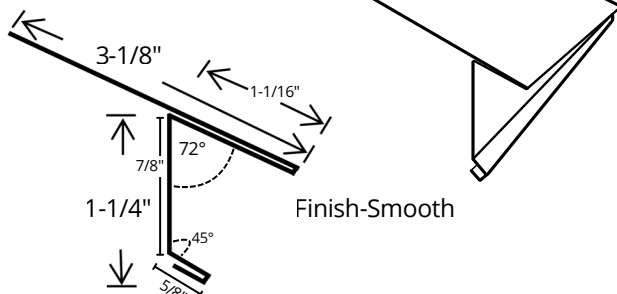

Notes: Copper Metallic & Dark Blue Panels and Trims - add 15%

Notes: Standard Hems are 1/2" - Variable Due to Trim Requirements

Galvanized Trims - Less 10%
Trims offered at 28 Gauge Steel
Upgrade to 26 Gauge Steel

Standing Seam Trims

SS Universal Rake (Smooth)

Part No.	Length	Specify Pitch & Indicate
SSUR	10' 5"	Open/Hidden

Universal Sidewall

Open	Part No.	Length
	US	10' 5"

Special Universal Rake

Part No.	Length	Open
SUR	10' 5"	

SS Endwall

Open	Part No.	Length
Specify Pitch	SSEW	10' 5"

Gutter Apron

Part No.	Length	Open
GU	10' 5"	Specify Pitch

SS Z Closure

Closed	Part No.	Length
	SSZC	10' 5"

SS D Edge

Part No.	Length
SSDE	10' 5"

Standing Seam Trims

1" SS Flat Cleat

Closed Hem
Use w/Rake Flashing
and Rake Cleat

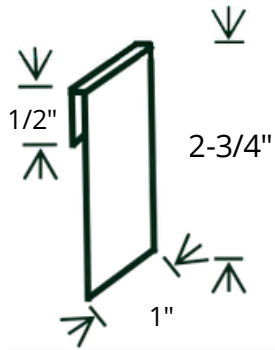

SS Counter Flashing

Closed Hem

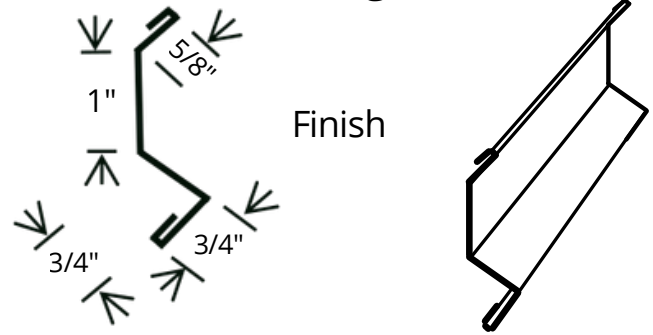

SS Rake Flashing

Closed Hem

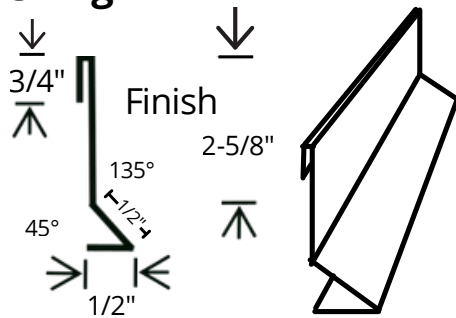

SS Universal Clip (20/Box)

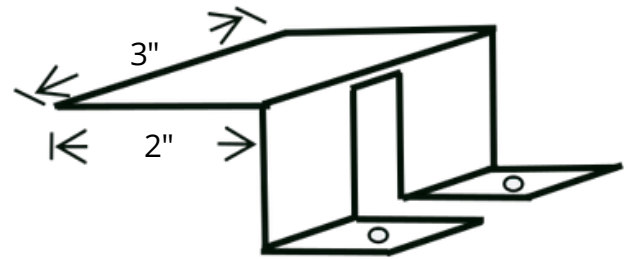

SS Cleat

Closed Hem

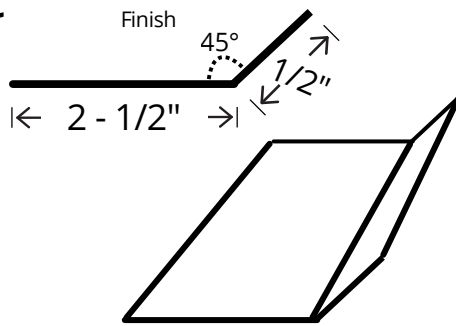

SS J Trim

Closed Hem

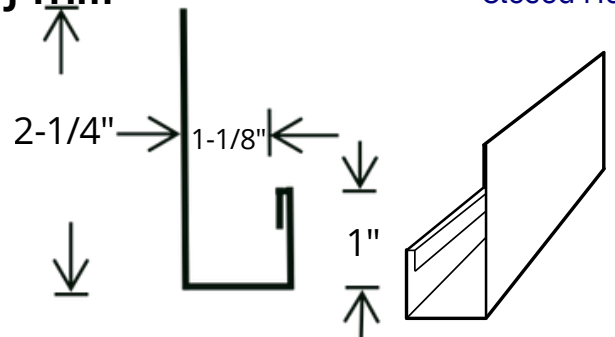

SS Off-Set Cleat

Closed Hem

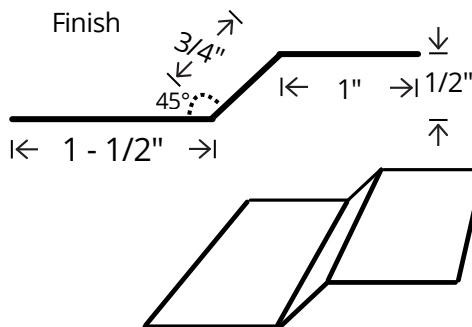

Notes: Copper Metallic & Dark Blue Panels and Trims - add 15%
Notes: Standard Hems are 1/2" - Variable Due to Trim Requirements

Galvanized Trims - Less 10%
Trims offered at 28 Gauge Steel
Upgrade to 26 Gauge Steel

Standing Seam Trims

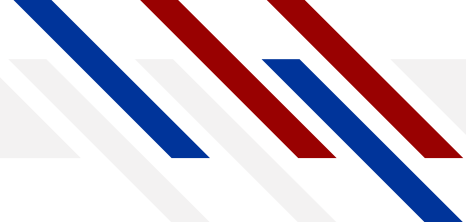

<p>1" SS Flat Cleat</p> <p>Part No. Length SSFC 10' 5"</p> <p>Closed Hem Use w/Rake Flashing and Rake Cleat</p>	<p>SS Counter Flashing Closed Hem</p> <p>Part No. Length SSCF 10' 5"</p>
<p>SS Rake Flashing Closed Hem</p> <p>Part No. Length SSRF 10' 5"</p>	<p>SS Universal Clip (20/Box)</p> <p>Part No. SSUC</p> <p>Used with CLOSURE FOAM SS Universal clip provides a large fastening area for any style ridge cap on a standing seam roof.</p>
<p>SS Cleat Closed Hem</p> <p>Part No. Length SSCL 10' 5"</p>	<p>SS J Trim Closed Hem</p> <p>Part No. Length SSJ 10' 5"</p>
<p>SS Off-Set Cleat Closed Hem</p> <p>Part No. Length SSOC 10' 5"</p>	

Standing Seam Trim Accessories

Wafer Head Hidden Fastener (250/Bag)



(250/Bag)

Part No.	Length
1WSWF	1"
15WSWF	1-1/2"
75SDWF	3/4"
1716SDWF	1-7/16"

Painted Low Profile Torx Fastener (250/Bag)



Part No.	Length
15WSLPT	1-1/2"
2WSLPT	2"

1/8" Stainless Steel Painted Rivets (100/Bag)



Part No.	Length
RIV	3/16"

Standing Seam Drip Edge Hem Tool



Part No.	Length
SSEDET	

Roof Snow Stop Color Insert (Specify color)

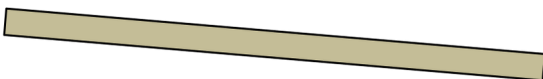

Part No.	Length
SSRSSINSERT	10' 5"

Roof Snow Stop 8' Prepunched Aluminum Bar 4" O.C.

Special Order

Part No.	Length
SSRSSBAR	8'

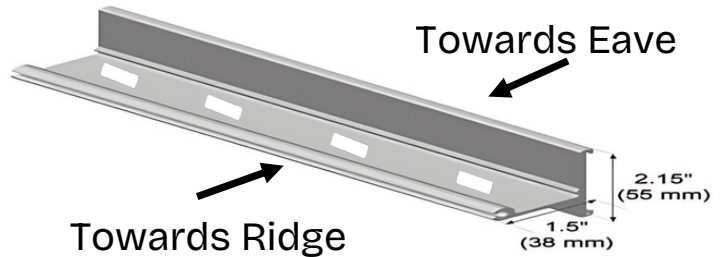

1. Attach Clamps on each rib for 8' bar (7 per bar/16" Panel)
2. Attach Aluminum Bar with screws on top of clamps
3. Attach Clips onto ridge side of bar (6 per bar/1 each pan)
4. Slide Color Insert into face plate towards eave

Roof Snow Stop Roof Clamp (7 per bar)

Special Order

Part No.
SSRSSCLAMP



Roof Snow Stop Snow Clip (6 per bar)

Special Order

Part No.
SSRSSCLIP





Commercial Trims



Commercial 28 Gauge Trims

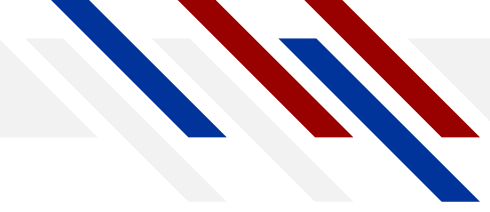

Mono-Slope Ridge

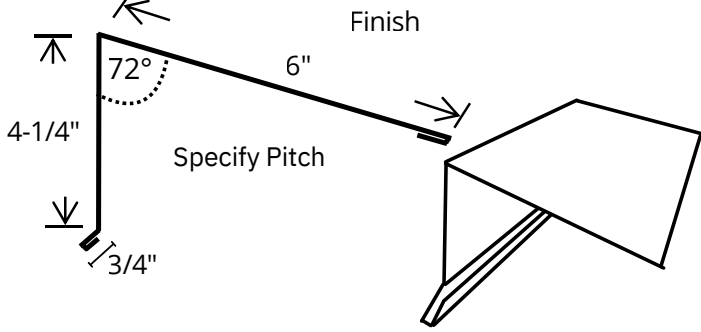

R-Panel Special Formed Ridge

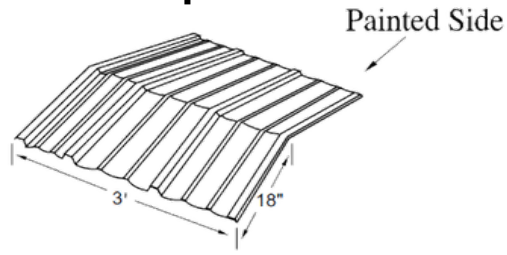

Com Universal Ridge

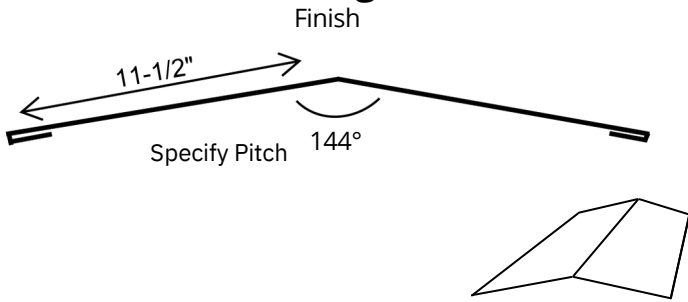

Gable End Cap

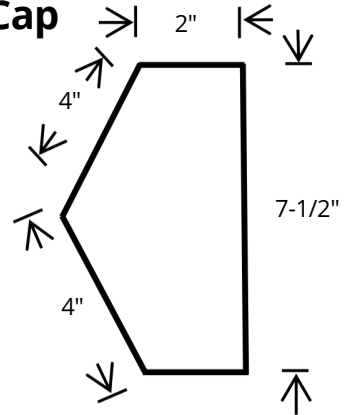

Com Rake

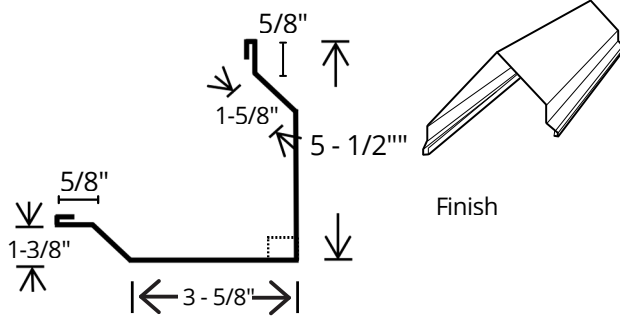

Com Eave Flashing

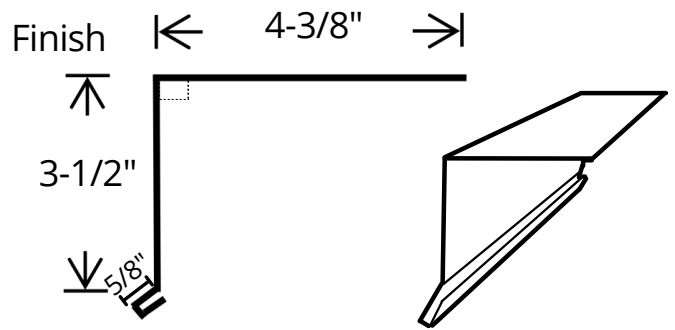

Gable End Closure

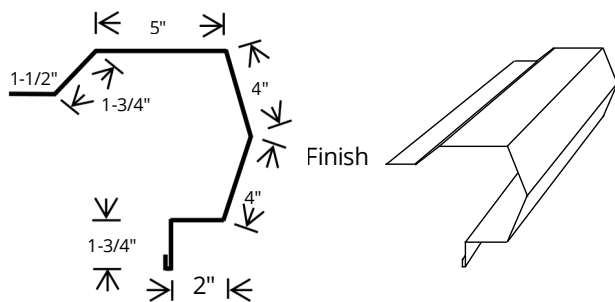

Com Outside Trim

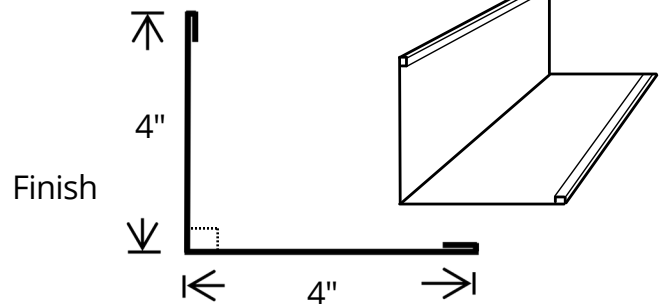

Notes: Copper Metallic & Dark Blue Panels and Trims - add 15%

Notes: Standard Hems are 1/2" - Variable Due to Trim Requirements

Galvanized Trims - Less 10%
Trims offered at 28 Gauge Steel
Upgrade to 26 Gauge Steel



Mono-Slope Ridge

Part No.	Length
MSRI	10' 5"

R-Panel Special Formed Ridge

Part No.	Length
RPXXRF2643	36"

Com Universal Ridge

Part No.	Length
COMURI10	10' 5"
COMURI20	20' 5"

Gable End Cap

Part No.	Length
GABCA	

Com Rake

Part No.	Length
COMRC10	10' 5"
COMRC12	12' 5"
COMRC14	14' 5"
COMRC16	16' 5"
COMRC18	18' 5"
COMOC20	20' 5"

Com Eave Flashing

Part No.	Length
COMEF10	10' 5"
COMEF20	20' 5"

Gable End Closure

Part No.	Length
GABCL10	10' 5"
GABCL20	20' 5"

Com Outside Trim

Part No.	Length
COMOT	10' 5"

Commercial 28 Gauge Trims



Com Inside Corner

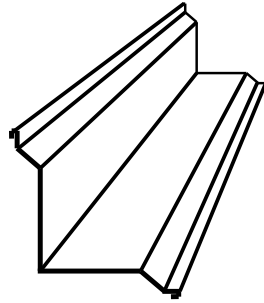
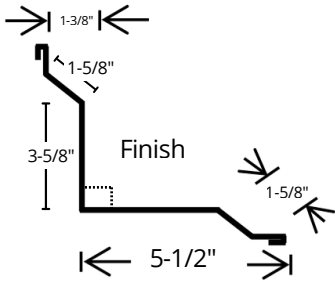

Com Overhead Door w/Drip

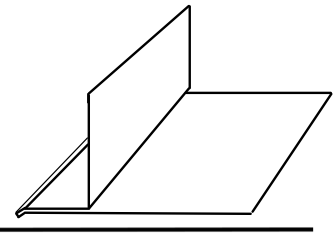
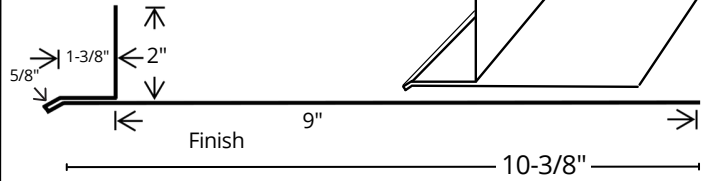

Com Universal Sidewall

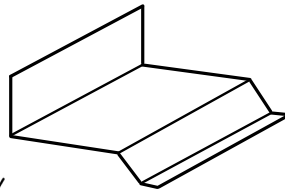
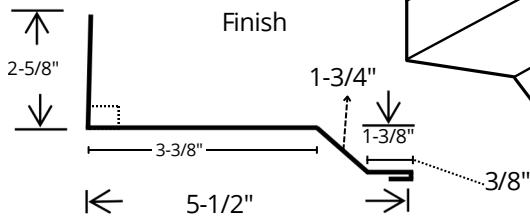

Com Overhead Door Jamb J

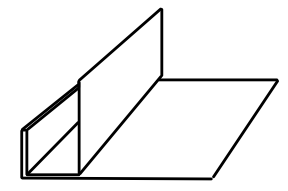
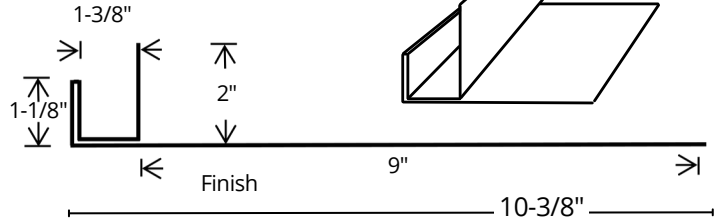

Endwall

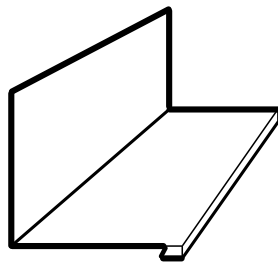
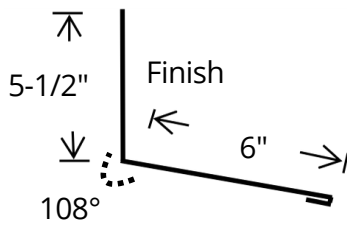

Com Drip Trim

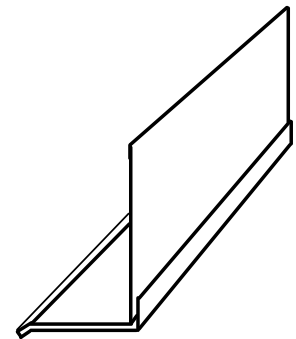
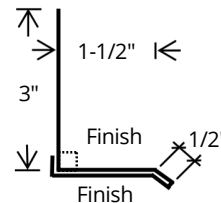

Com Header w/Drip

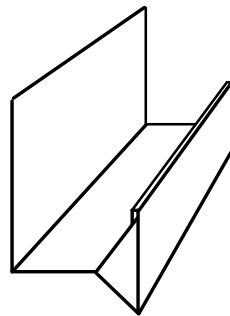
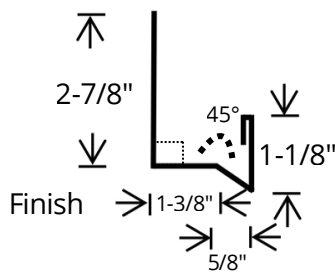

Com Window Sill Trim

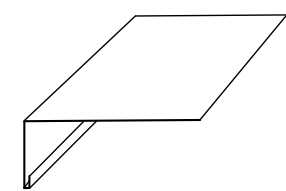
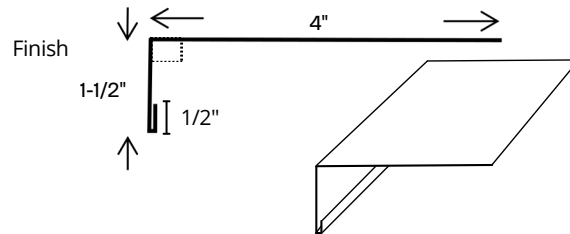

Notes: Copper Metallic & Dark Blue Panels and Trims - add 15%
 Notes: Standard Hems are 1/2" - Variable Due to Trim Requirements

Galvanized Trims - Less 10%
 Trims offered at 28 Gauge Steel
 Upgrade to 26 Gauge Steel

Commercial 28 Gauge Trims



Com Inside Corner Part No. COMINRC Length 10' 5"	Com Overhead Door w/Drip Part No. COMODD9 Length 10' 5"		Part No. COMODD9 Length 12' 5"	
	Part No. COMODD9 Length 14' 5"		Part No. COMODD9 Length 16' 5"	
	Part No. COMODD9 Length 18' 5"			
	Com Universal Sidewall Part No. COMUS10 Length 10' 5"		Com Overhead Door Jamb J Part No. COMOJJ9 Length 10' 5"	
	Part No. COMUS20 Length 20' 5"		Part No. COMOJJ9 Length 12' 5"	
Part No. COMUS20 Length 20' 5"		Part No. COMOJJ9 Length 14' 5"		
Part No. COMUS20 Length 20' 5"		Part No. COMOJJ9 Length 16' 5"		
Part No. COMUS20 Length 20' 5"		Part No. COMOJJ9 Length 18' 5"		
Endwall Part No. EW Length 10' 5"	Com Drip Trim Part No. COMDC10 Length 10' 5"		Part No. COMDC20 Length 20' 5"	
	Part No. COMDC20 Length 20' 5"			
Com Header w/Drip Part No. COMHTD10 Length 10' 5"	Com Window Sill Trim Part No. COMWS10 Length 10' 5"			
	Part No. COMHTD12 Length 12' 5"			
	Part No. COMHTD14 Length 14' 5"			

Notes: Copper Metallic & Dark Blue Panels and Trims - add 15%

Galvanized Trims - Less 10%
 Trims offered at 28 Gauge Steel
 Upgrade to 26 Gauge Steel

Commercial 28 Gauge Trims

Com Head Trim

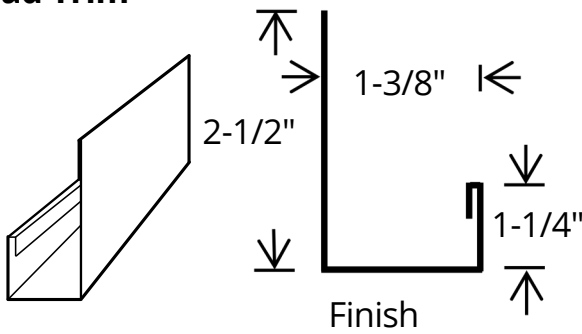

Com Base Closure

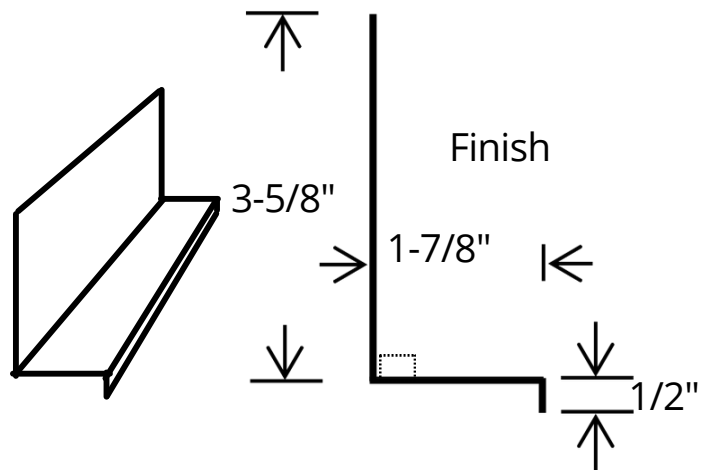

Com Double J Trim

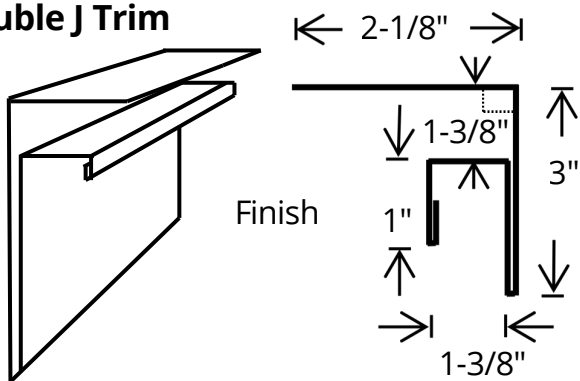

Com Rat Guard

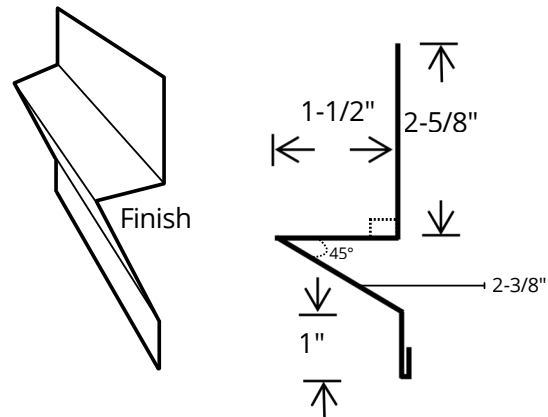

Com Jamb Trim

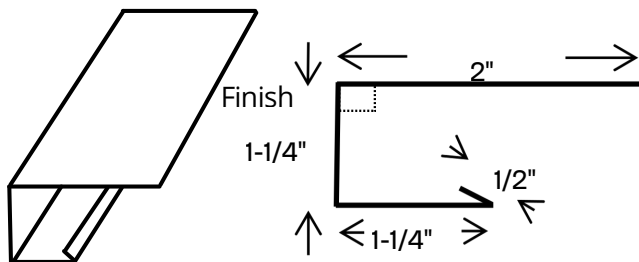

Com Transition

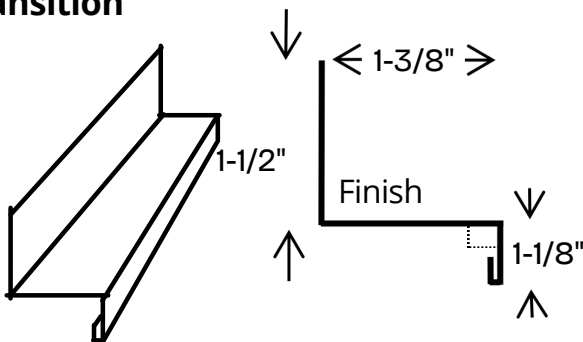

Com Masonry Flash

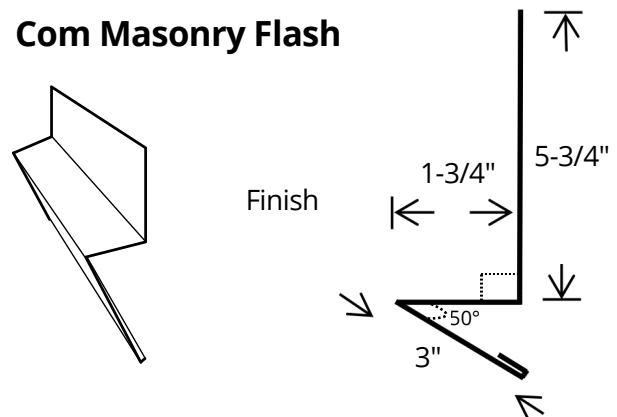

Notes: Copper Metallic & Dark Blue Panels and Trims - add 15%
 Notes: Standard Hems are 1/2" - Variable Due to Trim Requirements

Galvanized Trims - Less 10%
 Trims offered at 28 Gauge Steel
 Upgrade to 26 Gauge Steel

Commercial 28 Gauge Trims

Com Head Trim

Part No.	Length
COMHT10	10' 5"
COMHT12	12' 5"
COMHT14	14' 5"

Com Double J Trim

Part No.	Length
COMDJ	10' 5"

Com Jamb Trim

Part No.	Length
COMJT10	10' 5"
COMJT12	12' 5"
COMJT14	14' 5"

Com Transition

Part No.	Length
COMTR	10' 5"

Com Base Closure

Part No.	Length
COMBASE	10' 5"

Com Rat Guard

Part No.	Length
COMRG	10' 5"

Com Masonry Flash

Part No.	Length
COMMF10	10' 5"
COMMF20	20' 5"



Highland Rib Trims



Highland Rib 28 Gauge Trims

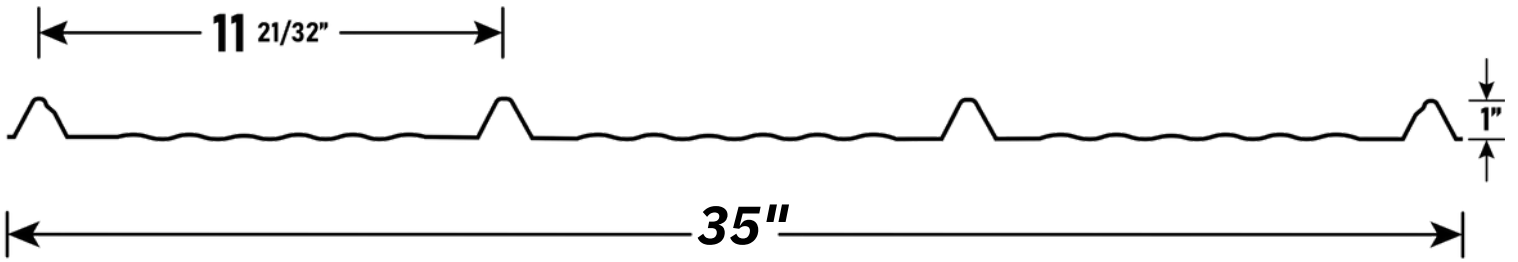

Rake & Corner

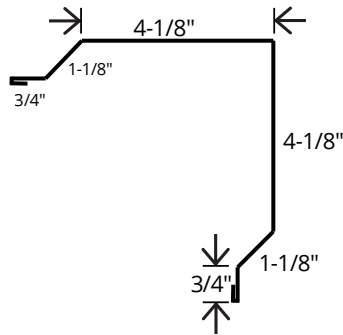
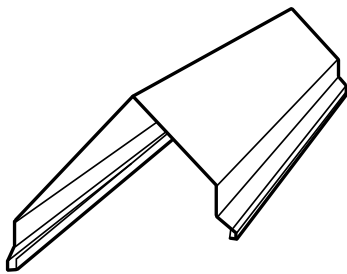

7" & 9" OH Door Jamb J

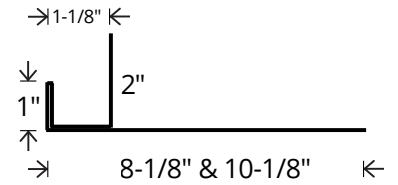
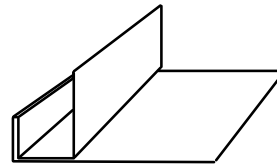

Mini-Rake & Corner

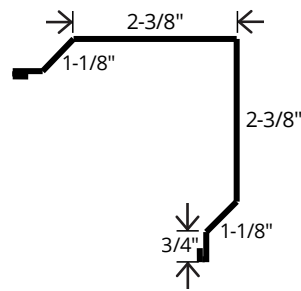
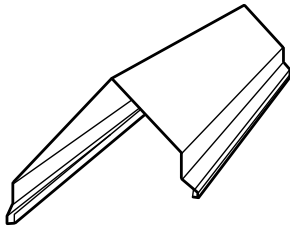

7" & 9" OH Door w/Drip

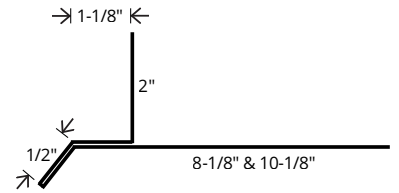
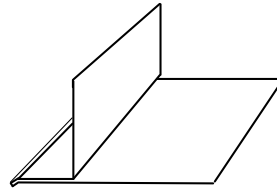

J-Channel

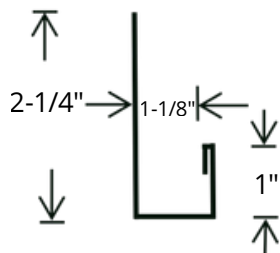
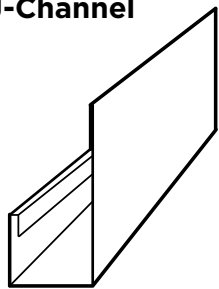

Universal Sidewall

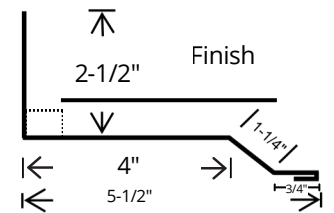
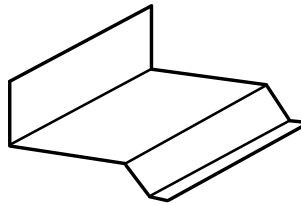

Notes: Copper Metallic & Dark Blue Panels and Trims - add 15%
 Notes: Standard Hems are 1/2" - Variable Due to Trim Requirements

Galvanized Trims - Less 10%
 Trims offered at 28 Gauge Steel
 Upgrade to 26 Gauge Steel



Rake & Corner

HRRC 10'5"

7" & 9" OH Door Jamb J

HROJJ7 10'5"

HROJJ9 10'5"

Mini-Rake & Corner

HRMR 10'5"

7" & 9" OH Door w/Drip

HRODD7 10'5"

HRODD9 10'5"

J-Channel

SSJ 10'5"

Universal Sidewall

HRUS 10'5"

Notes: Copper Metallic & Dark Blue Panels and Trims - add 15%
Notes: Standard Hems are 1/2" - Variable Due to Trim Requirements

Galvanized Trims - Less 10%
Trims offered at 28 Gauge Steel
Upgrade to 26 Gauge Steel

Highland Rib 28 Gauge Trims

Transition

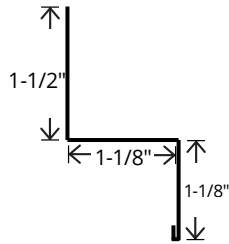
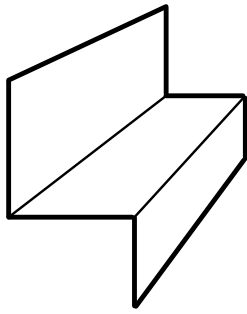

Inside Corner

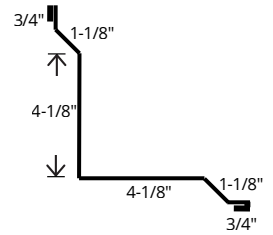
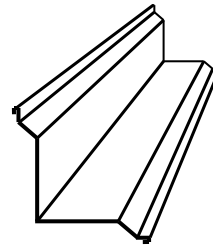

J-Channel

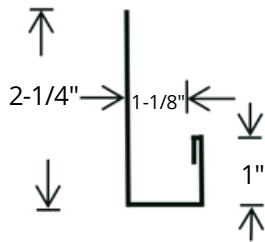
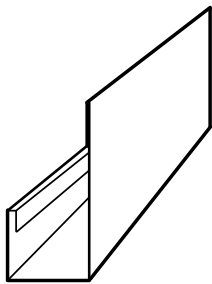

Drip Cap

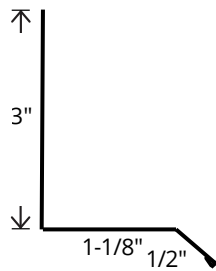
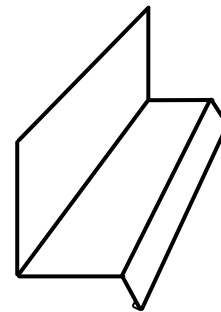

Rat Guard

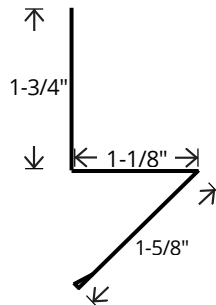
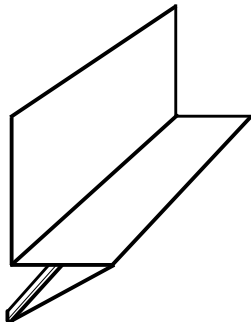

Starter/Box

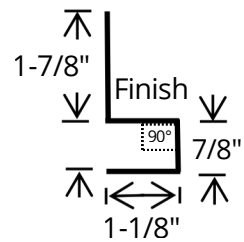
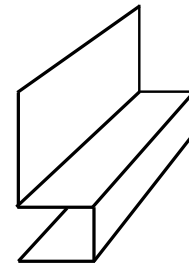

Soffit Starter

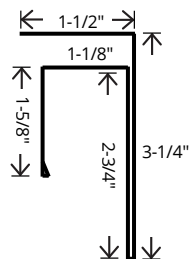
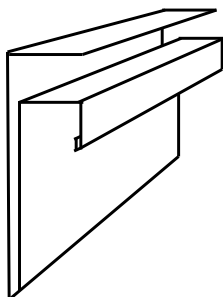



Transition

HRTR 10'5"

Inside Corner

HRINC 10'5"

J-Channel

SSJ 10'5"

Drip Cap

HRDC 10'5"

Rat Guard

HRRG 10'5"

Starter/Box

HRSX 10'5"

Soffit Starter

HRSOFS 10'5"



Low Rib Trims



Low Rib 28 Gauge Trims

LR Starter Trim

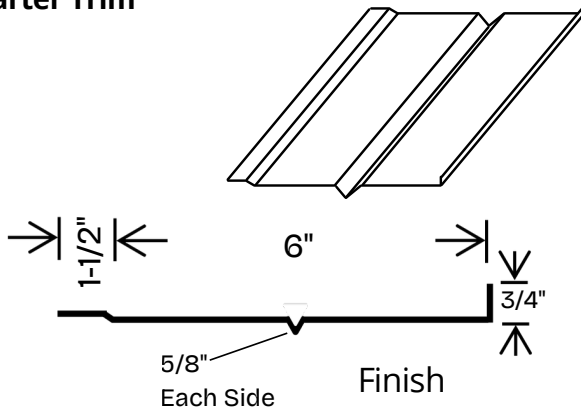

LR Hem Trim

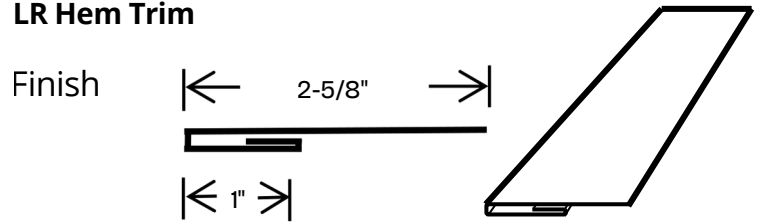

LR Top Molding

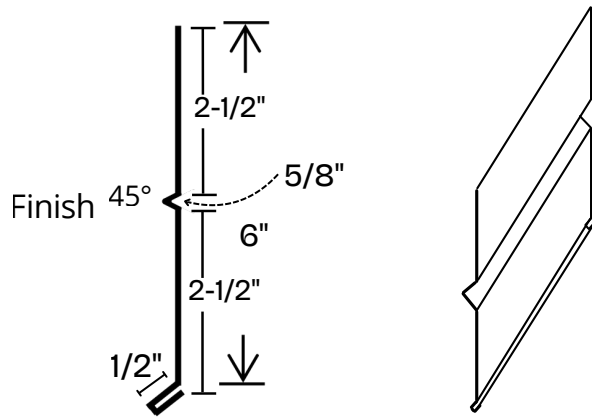

LR Transition

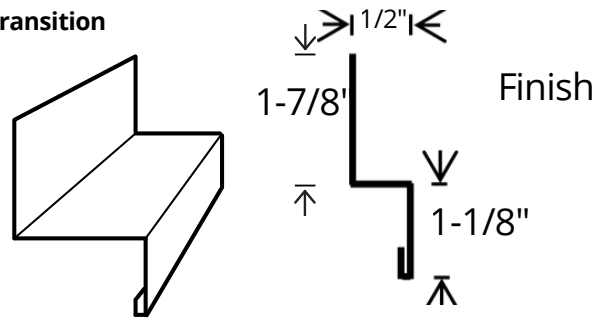

LR Base Moulding

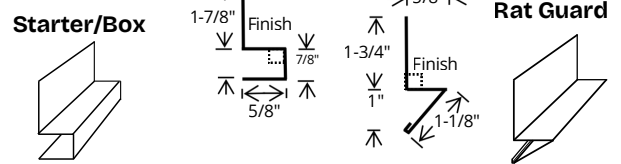

LR Outside Corner

(Recommend RC or COMOT as alternative trims)

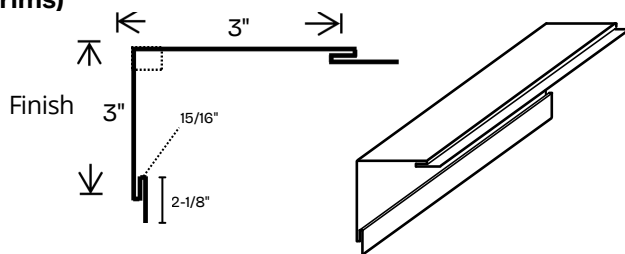

LR Overhead Door with Drip

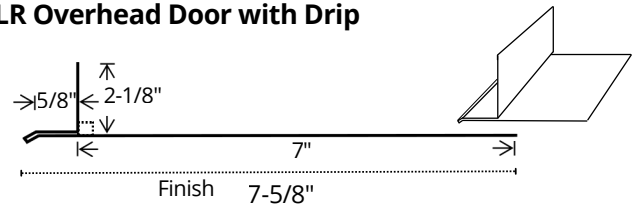

LR Overhead Door Jamb

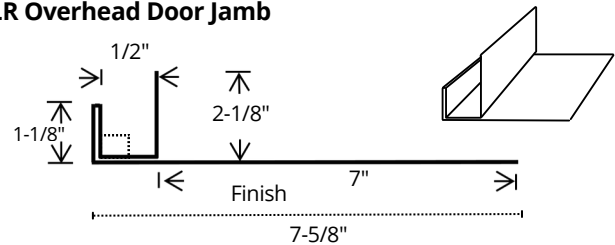

LR Divider Trim

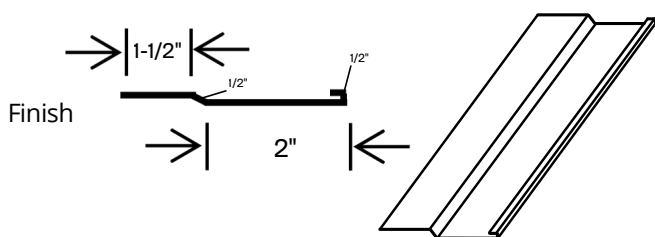

LR Drip Cap

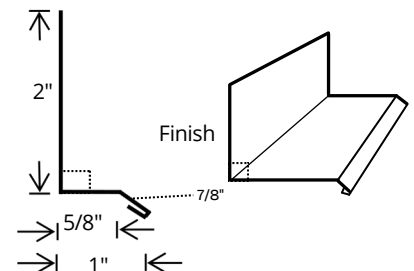

Notes: Copper Metallic & Dark Blue Panels and Trims - add 15%
Notes: Standard Hems are 1/2" - Variable Due to Trim Requirements

Galvanized Trims - Less 10%
Trims offered at 28 Gauge Steel
Upgrade to 26 Gauge Steel

Low Rib 28 Gauge Trims

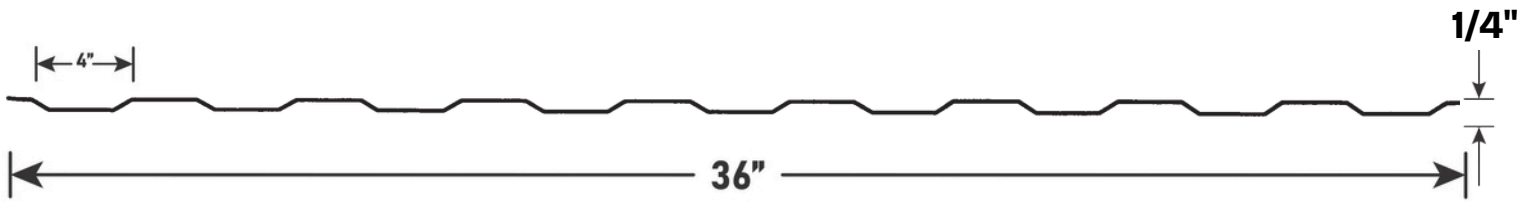

<p>LR Starter Trim</p> <table border="1"> <thead> <tr> <th>Part No.</th> <th>Length</th> </tr> </thead> <tbody> <tr> <td>LRST</td> <td>10' 5"</td> </tr> </tbody> </table>	Part No.	Length	LRST	10' 5"	<p>LR Transition</p> <table border="1"> <thead> <tr> <th>Part No.</th> <th>Length</th> </tr> </thead> <tbody> <tr> <td>LRTR</td> <td>10' 5"</td> </tr> </tbody> </table>	Part No.	Length	LRTR	10' 5"		
Part No.	Length										
LRST	10' 5"										
Part No.	Length										
LRTR	10' 5"										
<p>LR Top Molding</p> <table border="1"> <thead> <tr> <th>Part No.</th> <th>Length</th> </tr> </thead> <tbody> <tr> <td>LRTM</td> <td>10' 5"</td> </tr> </tbody> </table>	Part No.	Length	LRTM	10' 5"	<p>LR Base Moulding</p> <table border="1"> <thead> <tr> <th>Part No.</th> <th>Length</th> </tr> </thead> <tbody> <tr> <td>LRSX</td> <td>10' 5"</td> </tr> <tr> <td>LRRG</td> <td>10' 5"</td> </tr> </tbody> </table>	Part No.	Length	LRSX	10' 5"	LRRG	10' 5"
Part No.	Length										
LRTM	10' 5"										
Part No.	Length										
LRSX	10' 5"										
LRRG	10' 5"										
<p>LR Outside Corner (Recommend RC or COMOT as alternative trims)</p> <table border="1"> <thead> <tr> <th>Part No.</th> <th>Length</th> </tr> </thead> <tbody> <tr> <td>LROC</td> <td>10' 5"</td> </tr> </tbody> </table>	Part No.	Length	LROC	10' 5"	<p>LR Overhead Door with Drip</p> <table border="1"> <thead> <tr> <th>Part No.</th> <th>Length</th> </tr> </thead> <tbody> <tr> <td>LRODD</td> <td>10' 5"</td> </tr> </tbody> </table>	Part No.	Length	LRODD	10' 5"		
Part No.	Length										
LROC	10' 5"										
Part No.	Length										
LRODD	10' 5"										
<p>LR Divider Trim</p> <table border="1"> <thead> <tr> <th>Part No.</th> <th>Length</th> </tr> </thead> <tbody> <tr> <td>LRDT</td> <td>10' 5"</td> </tr> </tbody> </table>	Part No.	Length	LRDT	10' 5"	<p>LR Overhead Door Jamb</p> <table border="1"> <thead> <tr> <th>Part No.</th> <th>Length</th> </tr> </thead> <tbody> <tr> <td>LROJJ</td> <td>10' 5"</td> </tr> </tbody> </table>	Part No.	Length	LROJJ	10' 5"		
Part No.	Length										
LRDT	10' 5"										
Part No.	Length										
LROJJ	10' 5"										
<p>LR Hem Trim</p> <table border="1"> <thead> <tr> <th>Part No.</th> <th>Length</th> </tr> </thead> <tbody> <tr> <td>HT</td> <td>10' 5"</td> </tr> </tbody> </table>	Part No.	Length	HT	10' 5"	<p>LR Drip Cap</p> <table border="1"> <thead> <tr> <th>Part No.</th> <th>Length</th> </tr> </thead> <tbody> <tr> <td>LRDC</td> <td>10' 5"</td> </tr> </tbody> </table>	Part No.	Length	LRDC	10' 5"		
Part No.	Length										
HT	10' 5"										
Part No.	Length										
LRDC	10' 5"										

Notes: Copper Metallic & Dark Blue Panels and Trims - add 15%

Galvanized Trims - Less 10%
Trims offered at 28 Gauge Steel
Upgrade to 26 Gauge Steel



Board and Batten



Board and Batten Profile and Trims

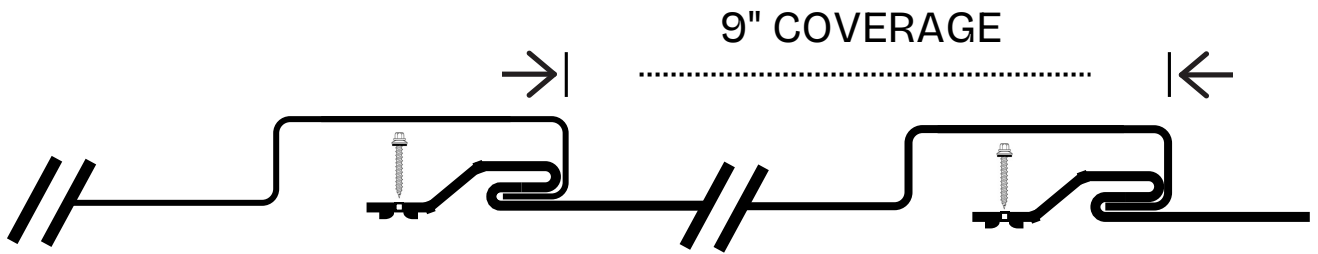
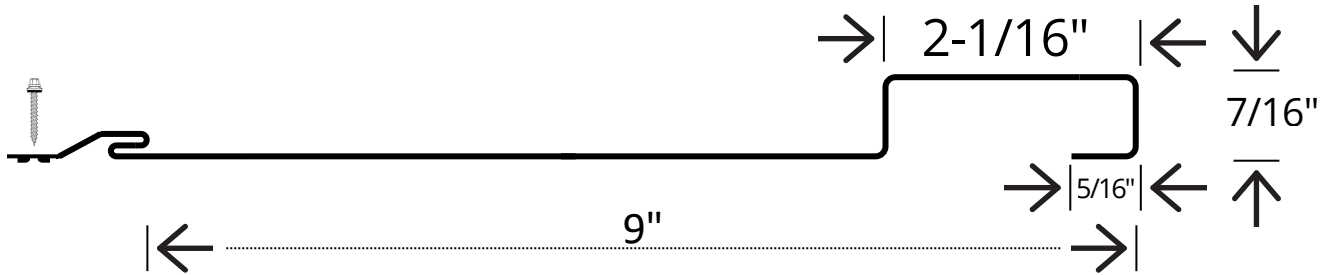

Silver Forest



Red Fawn



Iron Wood



American Elm

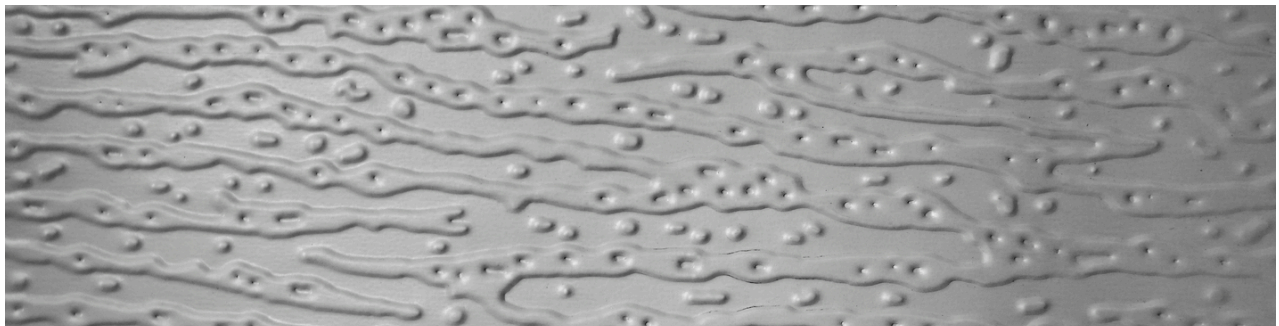

Notes: Copper Metallic & Dark Blue Panels and Trims - add 15%

Galvanized Trims - Less 10%

Notes: Standard Hems are 1/2" - Variable Due to Trim Requirements

Board and Batten Trims

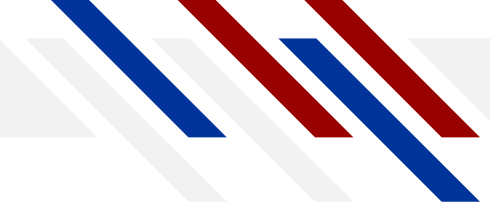

Inside Corner

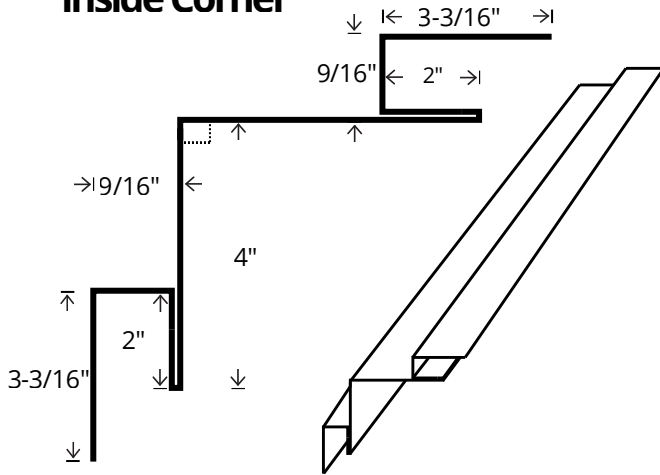

Outside Corner

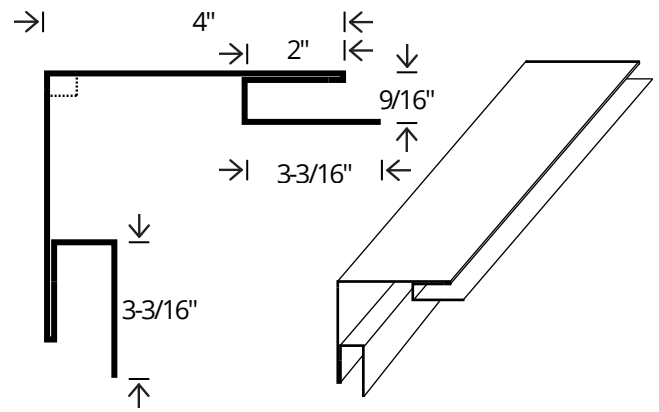

3" Band Board

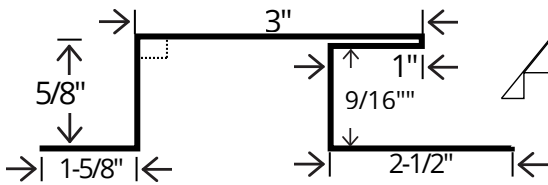

Window Cap Trim

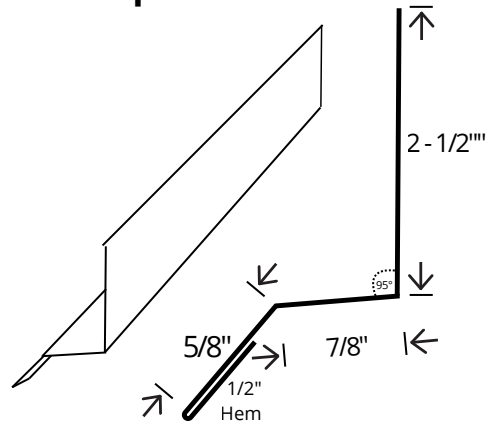

4" Band Board

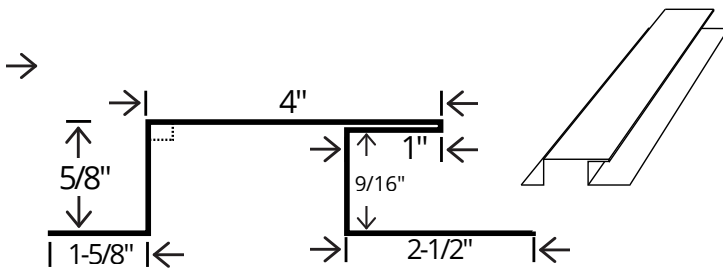

Hem Trim

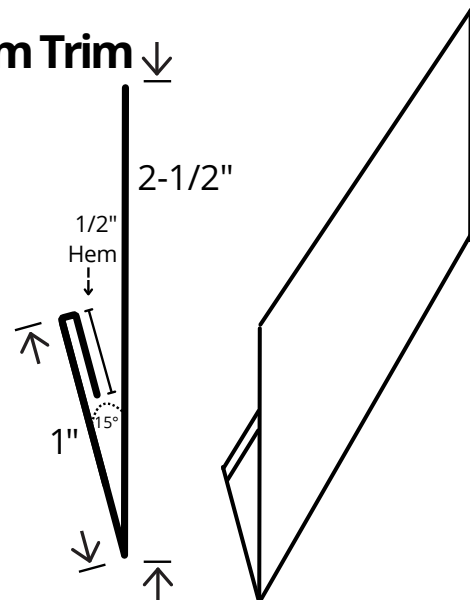

5.5" Band Board

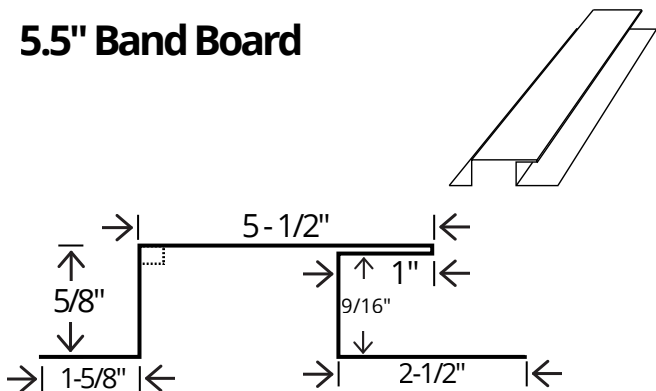

Notes: Copper Metallic & Dark Blue Panels and Trims - add 15%

Galvanized Trims - Less 10%
Trims offered at 28 Gauge Steel
Upgrade to 26 Gauge Steel

Notes: Standard Hems are 1/2" - Variable Due to Trim Requirements

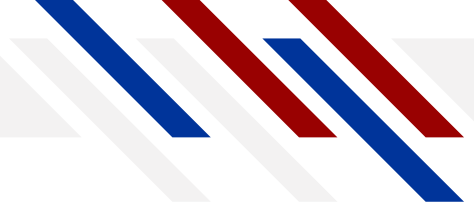

Inside Corner

Part No.	Length
BBIC	10' 5"

3" Band Board

Part No.	Length
BB3BB	10' 5"

4" Band Board

Part No.	Length
BB4BB	10' 5"

5.5" Band Board

Part No.	Length
BB5BB	10' 5"

Outside Corner

Part No.	Length
BBOC	10' 5"

Window Cap Trim

Part No.	Length
BBWC	10' 5"

Hem Trim

Part No.	Length
HT	10' 5"



Base Mouldings

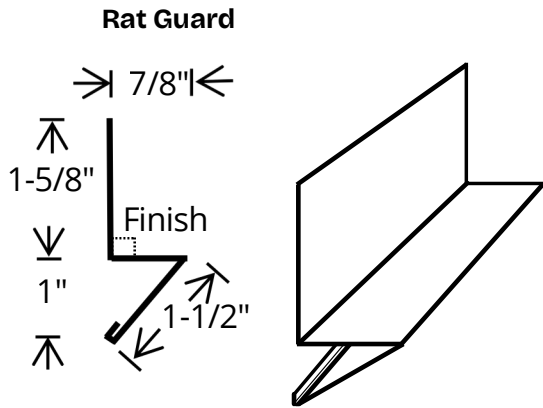

Transition - 1/2"

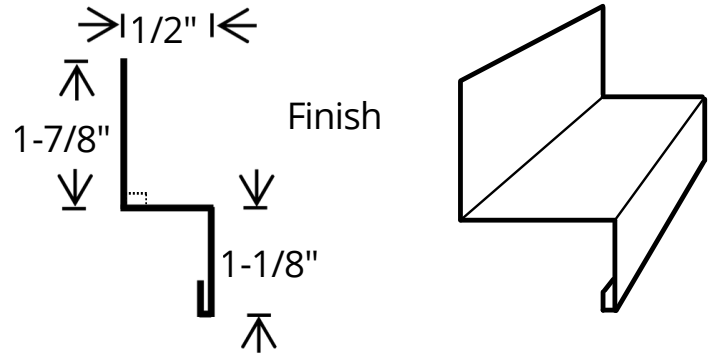

Starter/Box

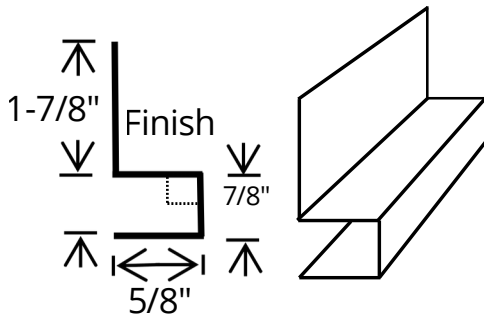

Double J 1/2"

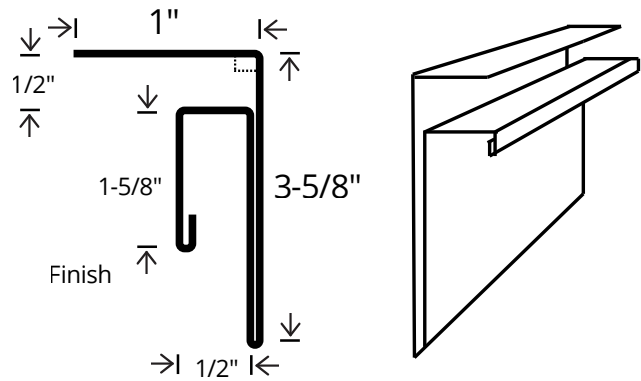

J Trim

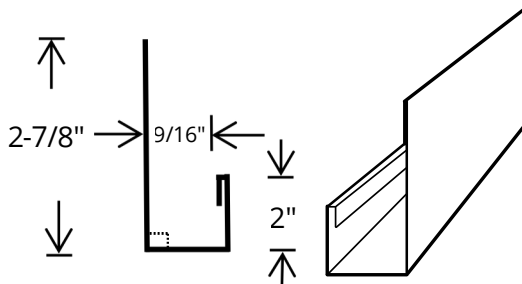

Notes: Copper Metallic & Dark Blue Panels and Trims - add 15%

Notes: Standard Hems are 1/2" - Variable Due to Trim Requirements

Galvanized Trims - Less 10%
Trims offered at 28 Gauge Steel
Upgrade to 26 Gauge Steel

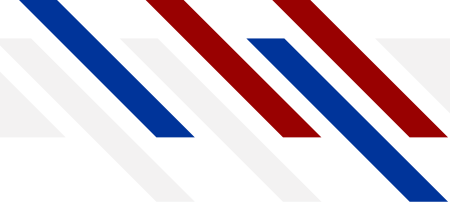

Base Mouldings

Starter/Box Rat Guard

Part No.	Length
BBSX	10' 5"
BBRG	10' 5"

Transition - 1/2"

Part No.	Length
TR12	10' 5"

J Trim

Part No.	Length
BBJ	10' 5"

Double J Trim

Part No.	Length
DJ12	10' 5"



T-BOARD

Tatanka Board Profile and Trims

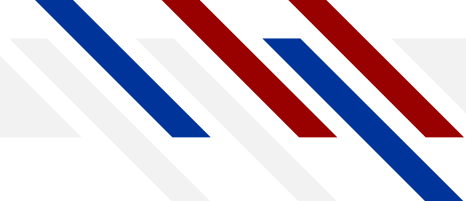

Silver Forest



Red Fawn



Iron Wood



American Elm



20 YEAR **WARRANTY**

Notes: Copper Metallic & Dark Blue Panels and Trims - add 15%

Galvanized Trims - Less 10%

Notes: Standard Hems are 1/2" - Variable Due to Trim Requirements

Tatanka Board Trims



Inside Corner

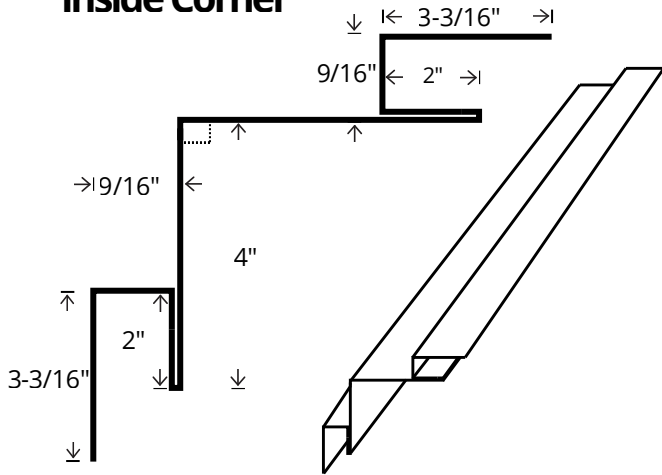

Outside Corner

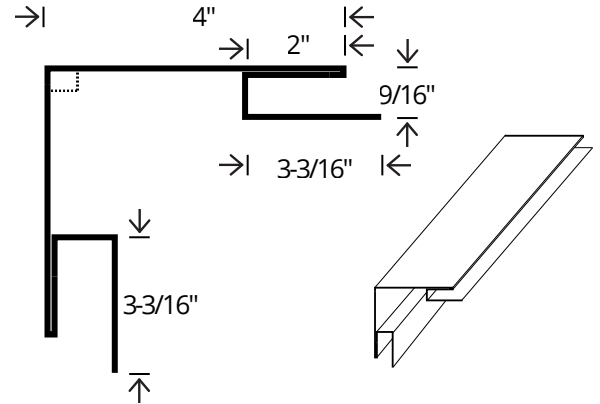

3" Band Board

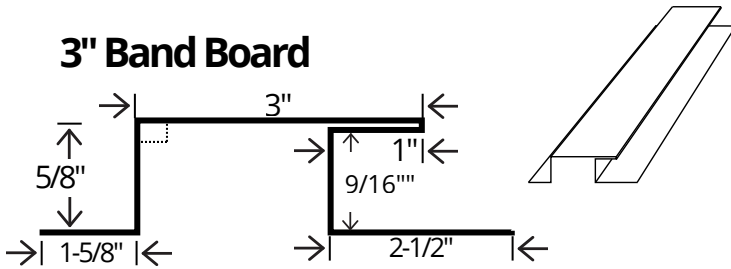

Window Cap Trim

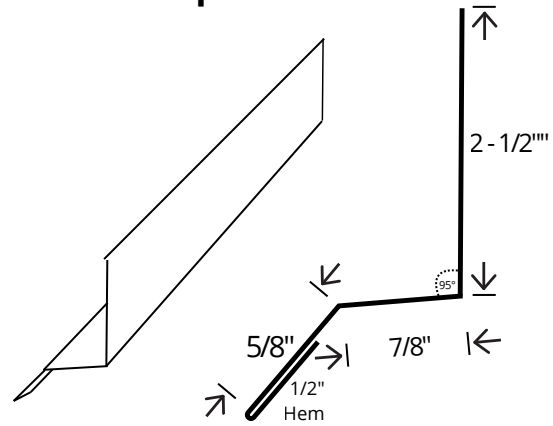

4" Band Board

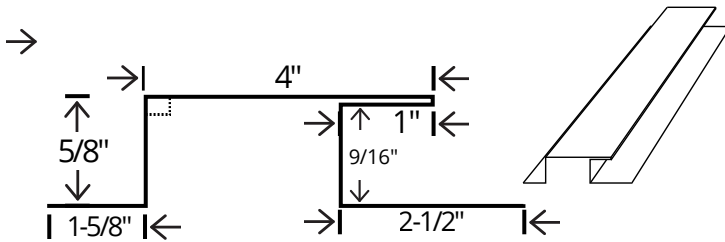

Hem Trim

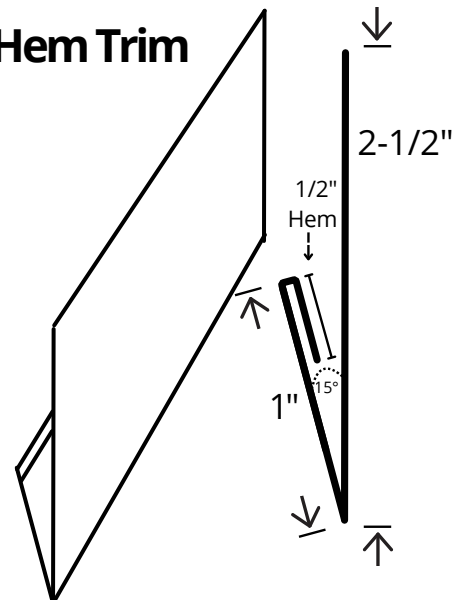

5.5" Band Board

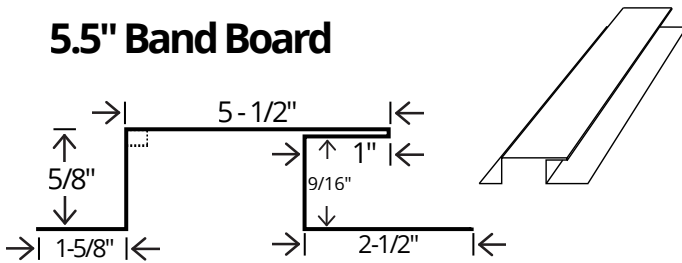

Notes: Copper Metallic & Dark Blue Panels and Trims - add 15%

Notes: Standard Hems are 1/2" - Variable Due to Trim Requirements

Galvanized Trims - Less 10%
Trims offered at 28 Gauge Steel
Upgrade to 26 Gauge Steel

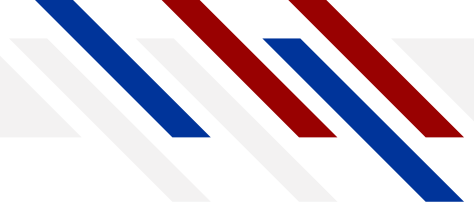

Inside Corner

Part No.	Length
TBBIC	10' 5"

3" Band Board

Part No.	Length
TBB3BB	10' 5"

4" Band Board

Part No.	Length
TBB4BB	10' 5"

5.5" Band Board

Part No.	Length
TBB5BB	10' 5"

Outside Corner

Part No.	Length
TBBOC	10' 5"

Window Cap Trim

Part No.	Length
TBBWC	10' 5"

Hem Trim

Part No.	Length
HT	10' 5"

Base Mouldings

Rat Guard

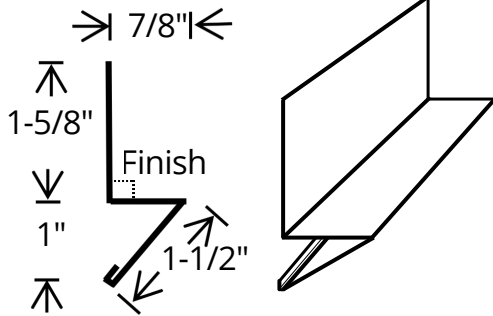

Transition - 1/2"

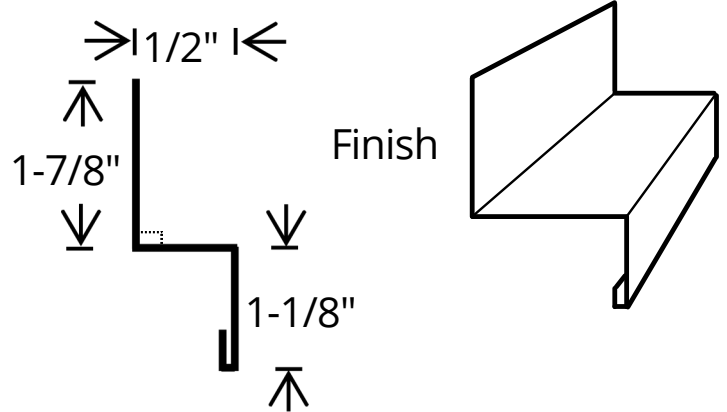

Starter/Box

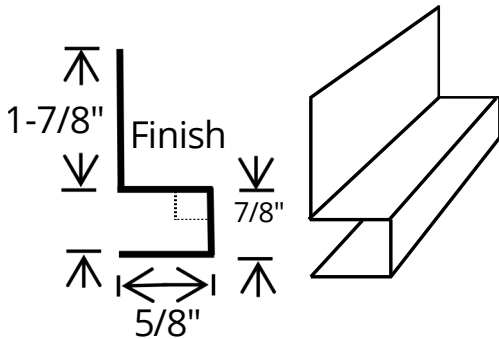

Double J 1/2"

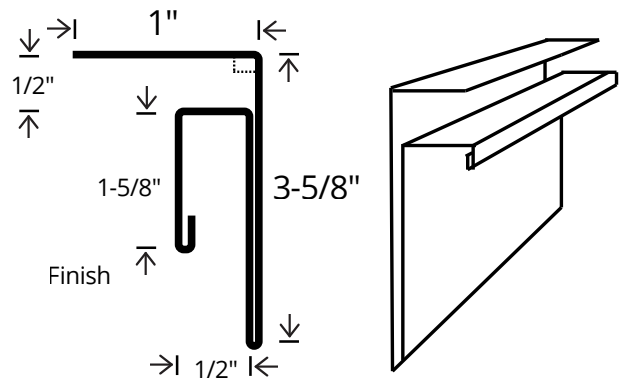

J Trim

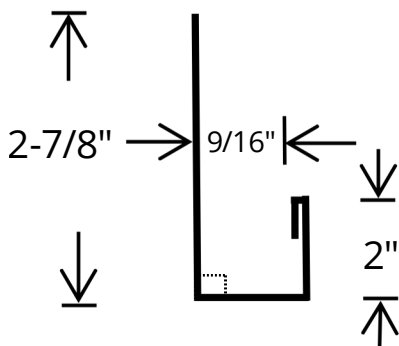

Notes: Copper Metallic & Dark Blue Panels and Trims - add 15%

Notes: Standard Hems are 1/2" - Variable Due to Trim Requirements

Galvanized Trims - Less 10%
Trims offered at 28 Gauge Steel
Upgrade to 26 Gauge Steel



Base Mouldings

Starter/Box Rat Guard

Part No.	Length
TBRG	10' 5"
TBSX	10' 5"

Transition - 1/2"

Part No.	Length
TR12	10' 5"

J Trim

Part No.	Length
TBJ	10' 5"

Double J Trim

Part No.	Length
DJ12	10' 5"
	10' 5"



DS Residential Products



3/8" F-Trim (Aluminum)

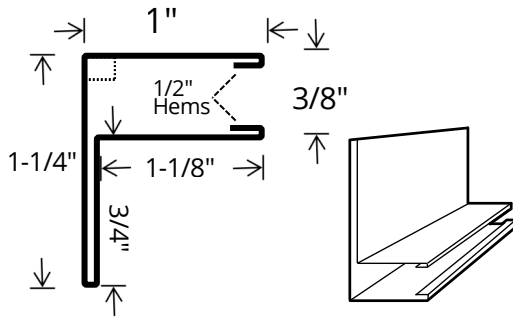

5-3/4" Wood Grain Aluminum

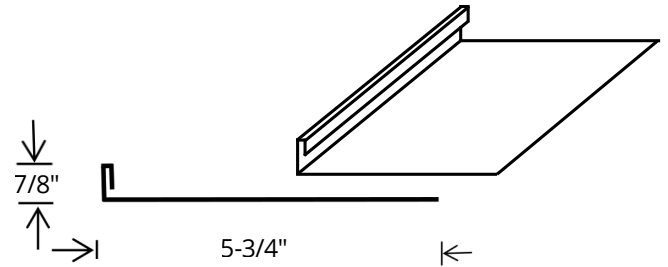

Mitre Divider Moulding (Aluminum)

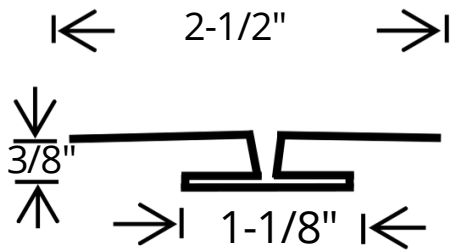

7-3/4" Wood Grain Aluminum

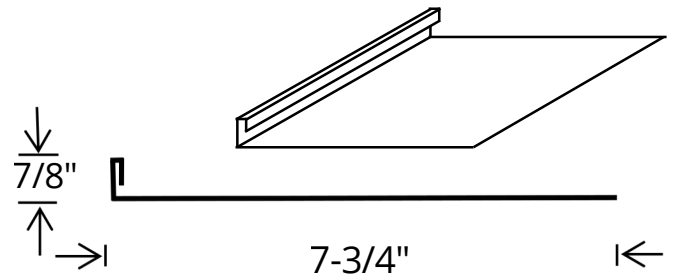

1/2" J-Channel (Aluminum)

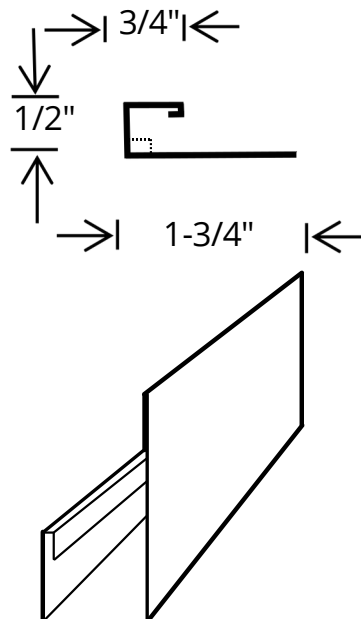

Aluminum Trim Coil 18-3/4" Wide



Notes: Copper Metallic & Dark Blue Panels and Trims - add 15%
 Notes: Standard Hems are 1/2" - Variable Due to Trim Requirements

Galvanized Trims - Less 10%
 Trims offered at 28 Gauge Steel
 Upgrade to 26 Gauge Steel

3/8" F-Trim (Aluminum)

Part No.	Length
FT38AL12	12'

Mitre Divider Moulding (Aluminum)

Part No.	Length
SOFDAL12	12'

1/2" J-Channel (Aluminum)

Part No.	Length
J12AL12	12'

5-3/4" Wood Grain Aluminum

	Part No.	Length
Aluminum	FA6WAL12	12'
Steel	FA6W10	10' 5"
Steel	FA6W12	12' 5"

7-3/4" Wood Grain Aluminum

	Part No.	Length
Aluminum	FA8WAL12	12' 10'
Steel	FA8W10	5" 12'
Steel	FA8W12	5"

Aluminum Trim Coil 18-3/4" Wide

Part No.	Length
DSCOAL25	25' 50'
DSCOAL50	

D Edge

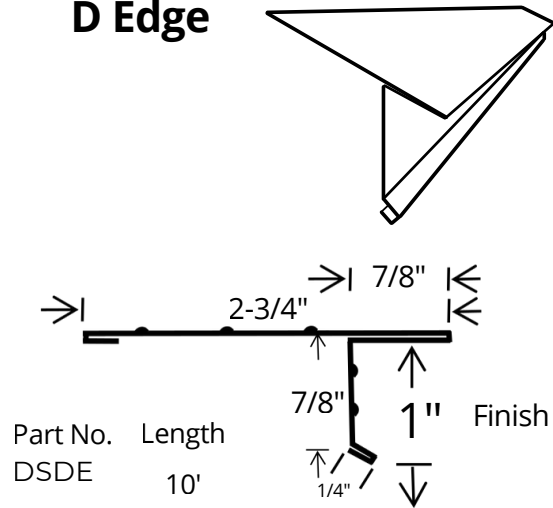

Part No. Length
DSDE 10'

Deck Flashing

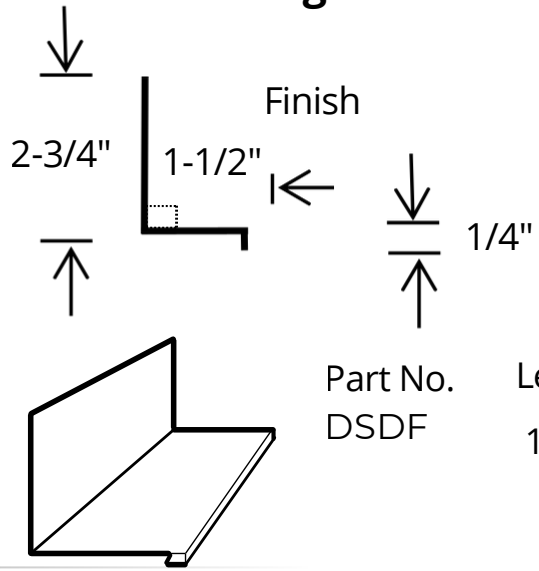

Part No. Length
DSDF 10'-5"

20" Valley (No Hems)

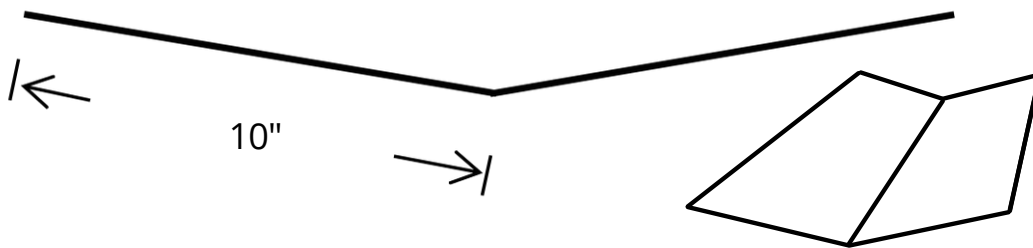

Part No. Length
DSV20 10'

Roll Valley 50' Galvanized

Part No.	Length
DSSVF12	50'
DSSVF16	50'
DSSFV20	50'
DSSFV24	50'

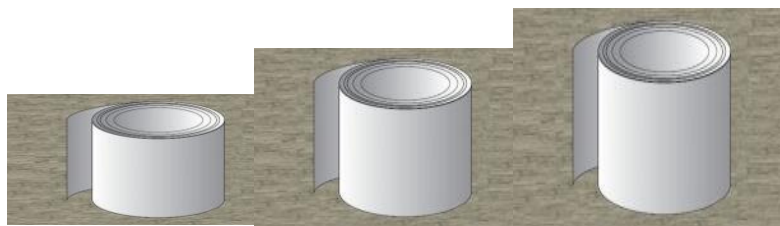

	Part No.	Length
20" W Valley w/Hems	DSWV20	10'
24" W Valley w/Hems	DSWV24	10'



Galvanized Trims - Less 10%
Trims offered at 28 Gauge Steel
Upgrade to 26 Gauge Steel







Notes: Standard Hems are 1/2" - Variable Due to Trim Requirements



Accessories

FASTENERS



Wood Screws

	1WS - 1" Metal to Wood Screws	#10 x 1" Screws Galvanized - Bag of 250 Painted - Bag of 250
	1WS_14 - 1" Metal to Wood Screws	#14 x 1" Screws Painted - Bag of 250 (#14 OSB or PLYWOOD)
	15WS - 1-1/2" Metal to Wood Screws	#10 x 1-1/2" Screws Galvanized - Bag of 250 Painted - Bag of 250
	2WS - 2" Metal to Wood Screws	#10 x 2" Screws Galvanized - Bag of 250 Painted - Bag of 250
	25WS - 2-1/2" Metal to Wood Screws	#10 x 2-1/2" Screws Galvanized - Bag of 250 Painted - Bag of 250
	3WS - 3" Metal to Wood Screws	#10 x 3" Screws Galvanized - Bag of 250 Painted - Bag of 250

Stainless Steel Screws

	1SSWS - 1" Stainless Steel	#10 x 1" Stainless Steel Screws Bag of 250
	15SSWS - 1-1/2" Stainless Steel	#10 x 1-1/2" Stainless Steel Screws Bag of 250
	(Special Order) 2SSWS - 2" Stainless Steel	#10 x 2" Stainless Steel Screws Bag of 250

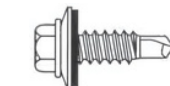
Lap Stitch Screws

	75LS - 3/4" Stitch Screws (1/4" HEAD)	#12x3/4" Stitch Screws Galvanized - Bag of 250 Painted - Bag of 250
	78LS - 7/8" Stitch Screws (5/16" HEAD)	#14x7/8" Mini-Driller Stitch Screws Galvanized - Bag of 250 - Painted - Bag of 250
	15WSLPT - 1-1/2" Wood	Painted Low Profile Torx Fastener (250/Bag)
	2WSLPT - 2" Wood	Painted - Bag of 250 - Painted - Bag of 250

Hidden Fasteners

Wafer Head Hidden Fastener Screws (250/Bag)



1WSWF - 1" Wafer Wood Screw
15WSWF - 1-1/2" Wafer Wood Screw

Bag of 250
Bag of 250



1SDPH - 1" Pancake Self-Drilling Screw
1716SDWF - 1-7/16" Wafer Self-Drill Screw

Bag of 250
Bag of 250

Self Drilling Screws

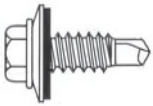

1SD - 1" Metal to Metal Screws #12 x 1" Screws

Galvanized - Bag of 250
Painted - Bag of 250



15SD - 1-1/2" Metal to Metal Screws #12 x 1-1/2" Screws

Galvanized - Bag of 250
Painted - Bag of 250

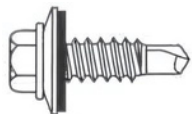

(Special Order)
2SD - 2" Metal to Metal Screws #12 x 2" Screws

Galvanized - Bag of 250
Painted - Bag of 250



RIV - 3/16" x 1/8" Painted Pop Rivets Stainless Steel Painted Rivets
Bag of 100

(For use with PVC and Polycarbonate materials)

Bag of 250



125OSW - 1-1/4" One-Stepper Screw White

125OSZ - 1-1/4" One-Stepper Screw Zinc

20SZ - 2" One-Stepper Screw Zinc



NUTSET14 1/4" Socket Bit

NUTSET1516 5/16" Socket Bit

NUTSET38 3/8" Socket Bit

Ridge Vents & Closures ~ Drop Ship Charges May Apply

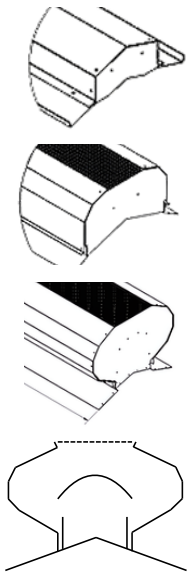

RV100 10' RV100 Ridgevents (5/8" Side Ventilation) *1.04 sq. feet of free area

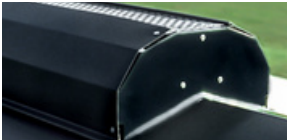

RV25 - Special Order 10' RV25 Ridgevents (With Top Ventilation)*2.1 sq. feet of free area
RV35 - Special Order 10' RV35 Ridgevents (With Top Ventilation)*2.5 sq. feet of free area

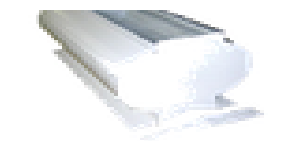

RV400 - Special Order 4' RV400 Ridgevents *3 sq feet of free area
 (Upcharge for Baffle)



RV900 - Special Order 10' RV900 Ridgevents *7.5 sq feet of free area
 (Upcharge for Baffle)

3' Foam-Glue Strip Top/Outer Closures Bottom/Inner Closures



Standing Seam areTop/Outer only

3' LP Ridge-vents Top/Outer Only



Standing Seam areTop/Outer only

- CLINSR / CLOTSR - Strong Rib Foam Closures
- CLINDR / CLOTDR - Dakota Rib Foam Closures
- CLINRP / CLOTRP - R-Panel Foam Closures
- CLINCR / CLOTDR - Continuous Rib Foam Closures
- CLINPR / CLOTPR - Pioneer Rib Foam Closures
- CLINQR / CLOTQR -Quad Rib Foam Closures
- CLSS32 - 32" Standing Seam Foam Closures (16" Panel)
- CLSS36 - 36" Standing Seam Foam Closures (12" Panel)
- CLLPSR - Strong Rib - Glued LP Ridge-vents
- CLLPDR - Dakota Rib - Glued LP Ridge-vents
- CLLPRP - R-Panel - Glued LP Ridge-vents
- CLLPPR - Pioneer Rib - Glued LP Ridge-vents
- CLLPQR - Quad Rib LP Ridge-vents
- CLLPSS32 - 32" Standing Seam LP Ridge-vents (16" Panel) -
- CLLPSS36 - 36" Standing Seam LP Ridge-vents (12" Panel)
- CLUV - 10' Uni-vent III Price each

Uni-vent III-DT[®]

the universal ventilation system

- Standard 1" x 2" x 10' pieces (10/box)
- Stock one product to match any roof panel configuration
- Apply directly to ridge cap
- Pure Polyurethane Foam
- Vinyl Coating
- UV Stabilized/Fire Retardant
- Continuous Glue Strip

1st - Roll the Uni-vent on top the panels

2nd - install the clips, pinches the closure at the high rib of the panel

3rd - install the ridge cap, attaching to the clip but next to the high rib

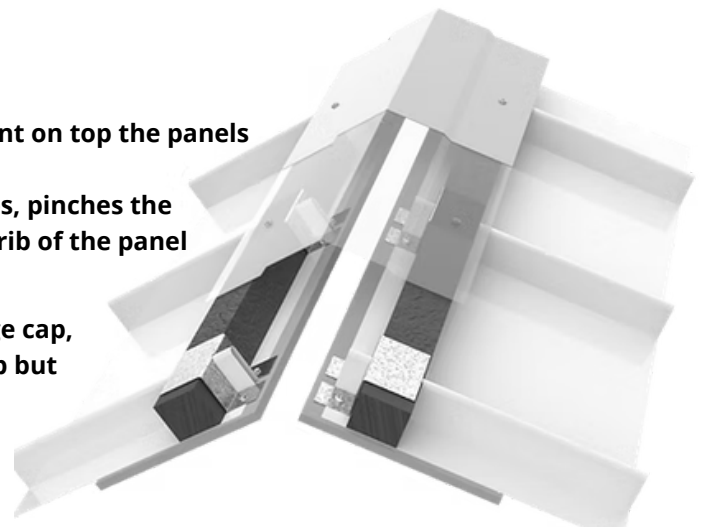

Uni-vent III will conform to virtually any roof panel configuration. It compresses and fills every void between your ridge cap and the roof panel. Factory applied glue strips allow the installer to roll out Uni-vent III and apply it to the ridge cap, even in windy conditions. Then, fasten to vented ridge cap to finish off the installation

RidgeVents & W-Vallery Closures

UNI-SEAL - Valley & Hip Closure Material

CLUST1 - 1" x 1" 20' Roll Price each

CLUST5 - 1-1/2" x 1-1/2" 20' Roll Price each

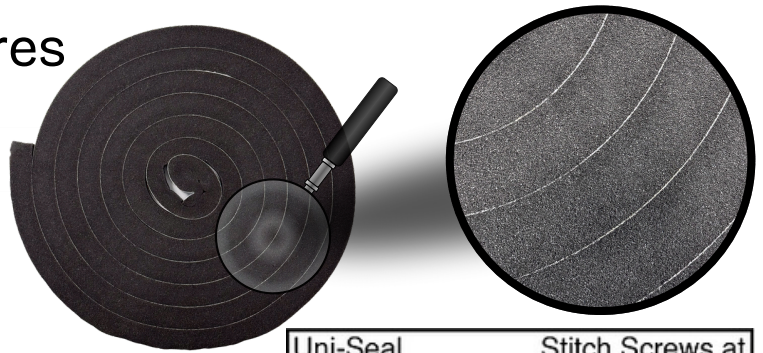

Factory Applied Glue Strip

- Pure Polyurethane Foam
- Vinyl Coating
- UV Stabilized/Fire Retardant
- Continuous Glue Strip

Valley & Hip Applications

- Eliminates the need for angle cut closures

Hip Application

- For Hip Application, apply the Uni-Seal approximately 1/2" from edge of ridge cap and fasten through the high rib with stitch screws

Valley Application

- Apply Uni-Seal in valley approximately 1/2" from the edge of roofing. Width of valley and roofing fasteneres per the manufacturers instructions

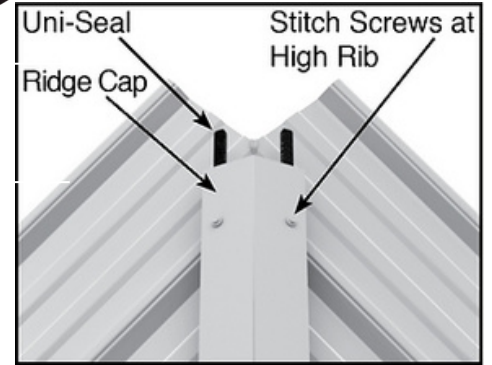

EMSEAL AST Hi-Acrylic

CLEM1 - 1" x 1" 20' Roll Price each

Higher levels of compression offer greater protection

* Watertight up to 5 PSF per ASTM E-331 modified to run 24 hours instead of standard 15 minutes. This equates to a 1-inch standing head of water for 24 hours without leakage.

Compression Levels

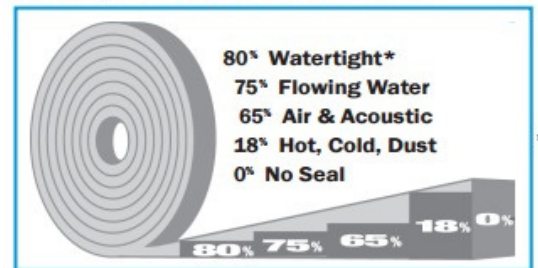

Hip

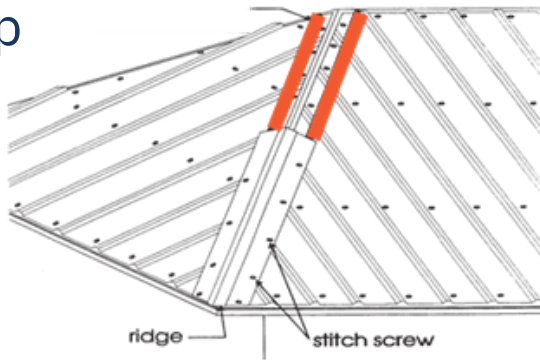

Valley

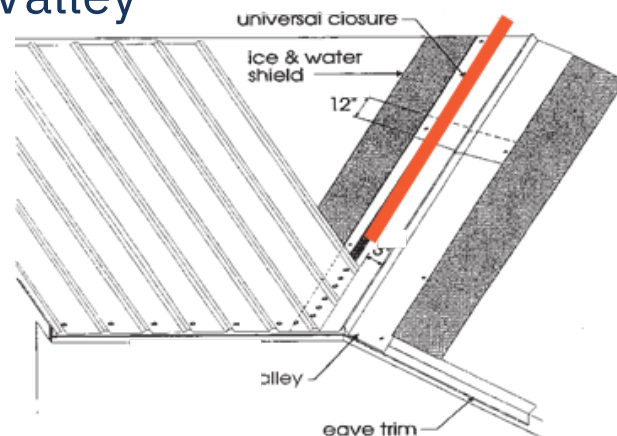

Ridge

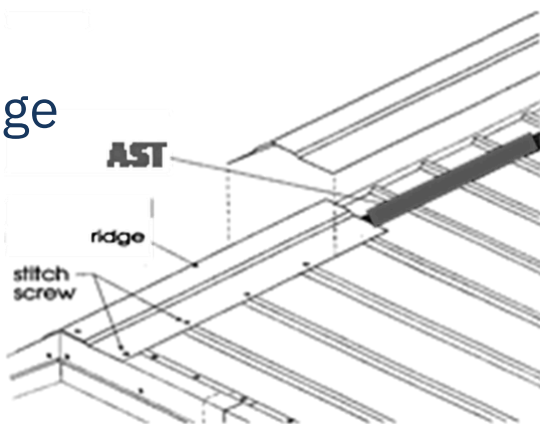



Coil Stock

Custom Width and Lengths Available - 26 & 28 Gauge



Flat Stock

Width
48"

Length
10'

28 Gauge

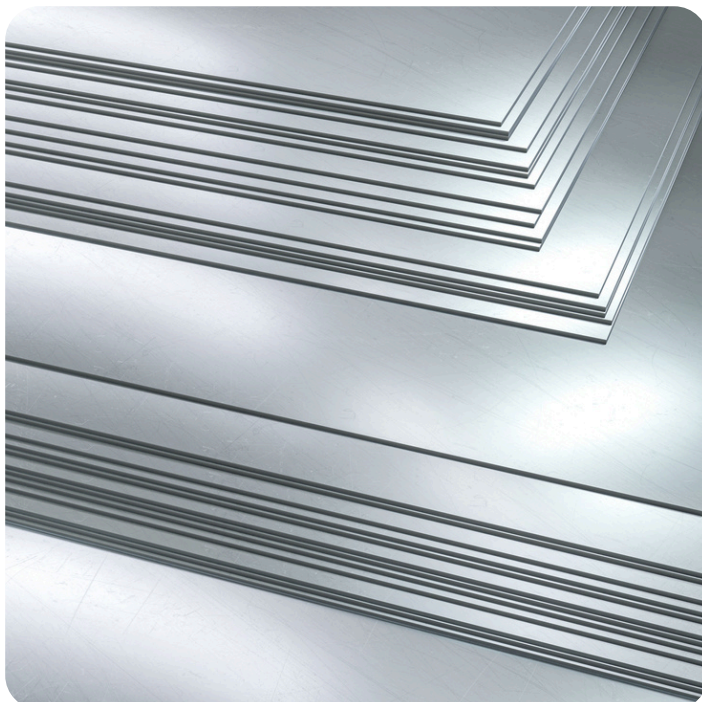

HydraShield Ice & Water Shield (240 Degrees)

ICEANDWATER3667 - 36" x 67'

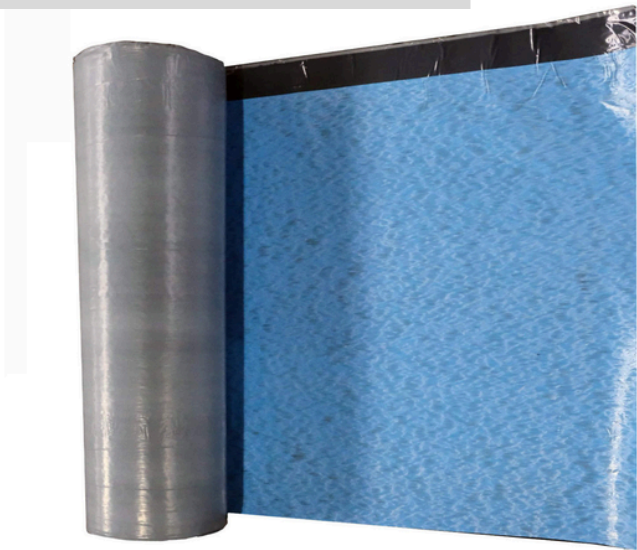

Hydrashell Synthetic Roofing Underlayment

UNDERLAYMENT40300 - 40" x 300'



Miscellaneous Accessories

PAINT - Touch Up Pen **PAINTBOTTLE**

- Bottle with Cap Brush 2 oz



Snow Guards (Clear in Stock)

3" x 3" x 5"

SNOWG-POLARBLOCK

Snow Stop found on page 14



CAULK

Metal Roof Polymer Sealant

CAULKCLEAR CAULKWHITE



Butyl Tape

BUT38 - Butyl Tape 3/32" x 3/8 - 45' Roll

BUT34 - Butyl Tape 3/32" x 3/4 - 50' Roll



Roof Flashers

RF3 (Black) - Standard 1/4" - 5"

RF# (Black) - Standard
RF#HT (Red) - High Temp

RF3HT (Red) - High Temp

RF5 / RF5HT - #5 4-1/4" - 7-3/4"

RF8 / RF8HT - #8 7" - 13"

RF9 / RF9HT - #9 9" - 19"

RFSB1S - SPLIT BOOT SQUARE 1/2" - 4"

RFSB2S/RFSB2HTS - SPLIT BOOT SQUARE 4" - 9-1/4"

RFSB3S - SPLIT BOOT SQUARE 9-1/4" - 16-1/4"



PVC Material

**Strong Rib Ag Liner--Special order -2 weeks
Continuous Rib Ag Liner--Special order -2 weeks**

Special Advantages to PVC Liner Panels:

1. Chemical Resistance: Unlike metal panels, PVC panels are not prone to corrosion from chemicals.
 2. Moisture Resistance: PVC Liner panels are highly resistant to moisture, making them ideal for environments where humidity and water exposure are common
 3. Thermal Insulation: PVC Panels provide better thermal insulation compared to metal panels
- Liner Panels have been installed in various agricultural facilities to meet stringent hygiene standards and requirements and provide easy-to-clean surfaces
 - In food prep and storage areas, maintaining high hygiene standards is crucial. PVC liner panels have been successfully used in these environments to provide a clean, low-maintenance, and durable surface
 - PVC Liner panels are ideal for vehicle wash bays due to their resistance to moisture and chemicals. They provide a durable and easy to clean surface that can withstand the harsh conditions of frequent washing
 - The panels have been installed in commercial kitchens where hygiene and ease of cleaning are paramount. Their resistance to mold, mildew, and most chemicals makes them an excellent choice for these environments

PVC Ag Panel

(special order for custom lengths)

Part No. Length

PVCSRLP20 20' 4"

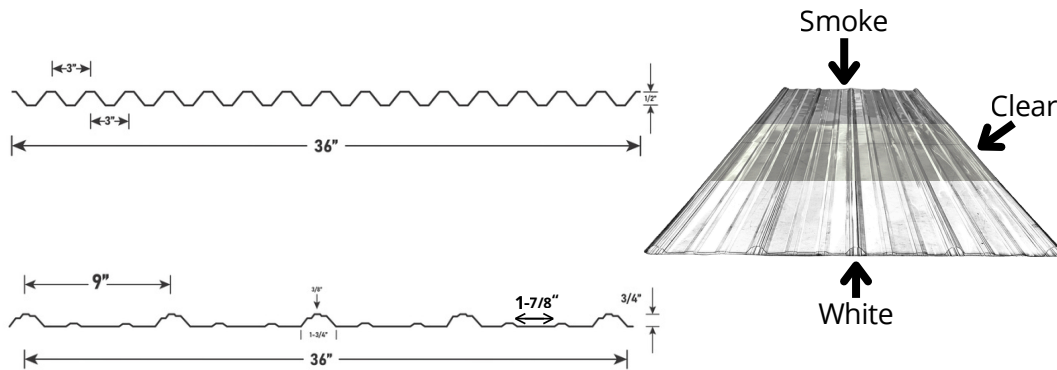

StrongRib Ag Liner-36" Coverage

Polycarbonate Strong Rib Skylight Panels

Part No.

Length

Polycarbonate Skylight Panels (Clear-90% ~ Smoke-80% ~ White-70%)

{STRONGRIB WHITE 8' AND 10' are not stocked} WHITE IS SPECIAL ORDER

SKCLEAR8	8'
SKCLEAR10	10'
SKCLEAR12	12'

Polycarbonate Skylight Panels (Pioneer Rib and R-Panel CLEAR)

SKCLEAR12XX 12'

Polycarbonate Skylight Panels (Dakota Rib CLEAR)

SKCLEAR12DR 12'

PVC Ag Panel Accessories



PVC J-Trim 1-1/4" One-Stepper

J7810PVC 10'

White Painted Screw (500/Bag)

125OSW 1-1/4"

1-1/4" One-Stepper Zinc Screw (500/Bag)

125OSZ 1-1/4"

2" One-Stepper Zinc Screw (500/Bag)

20SZ 2"

Skylights

Strong Panel[®] 5 oz Fiberglass Skylite

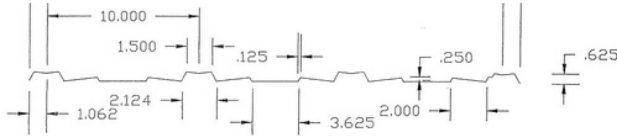

Part No.	Length
SKWHITEGLAS-SP3212	10" OC, 32" Coverage

ONLY IN - CLEAR, WHITE, SMOKE

Smooth Translucent White

Clear Continuous Rib Skylite

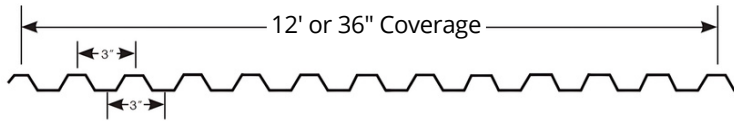

Part No.	Length
SKCLEARCR12-C	12'

ONLY IN - CLEAR, WHITE, SMOKE

24" Ridgelite Ridge Cap

1" Ridgelite Support Bracket

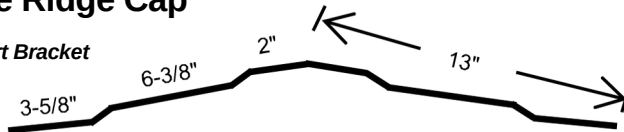

Part No.	Length
RIL	10' 6"
RILBK	1"

ONLY IN - CLEAR, WHITE, SMOKE

Polycarbonate Ridgelite (Clear-90% ~ Smoke-80% ~ White-70%)

MWI Cupolas

Special Order

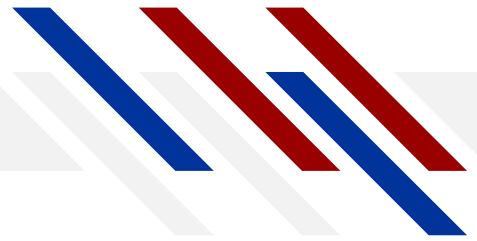

CUPOLA ROOF

Model: C240/C360/C480/C660

- 24" x 24", 36" x 36", 48" x 48", 66" x 66"
- Installs on top of the side sections
- Ships knocked down (66" is assembled)

Optional Base Trims:



Copper, Gallery Blue, Light Brown

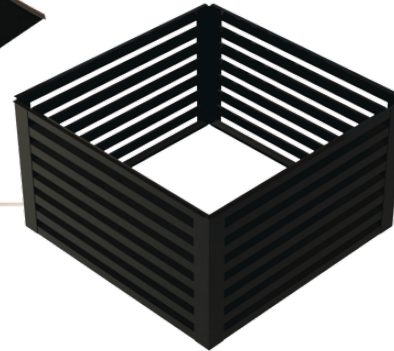
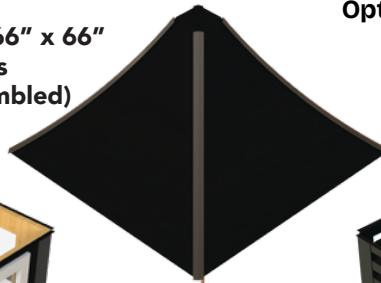
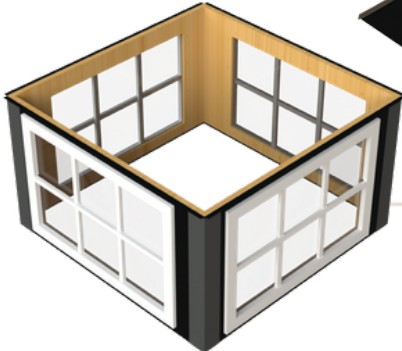

CUPOLA SIDES W/ WINDOWS

Model: C245W/C365W/C485W/C665W

- 24" x 24", 36" x 36", 48" x 48", 66" x 66"
- Installs on top of the flashing
- Ships knocked down (66" ships assembled)
- (36" shown above)

CUPOLA SIDES W/ LOUVERS

Model: C245/C365/C485/C665

- 24" x 24", 36" x 36", 48" x 48", 66" x 66"
- Installs on top of flashing
- Ships knocked down (66" ships assembled)

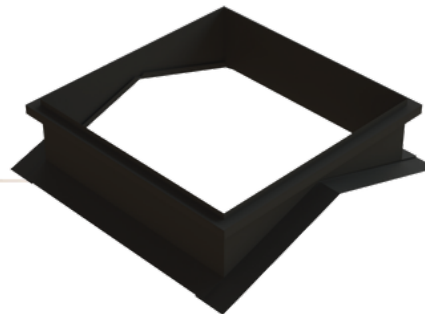
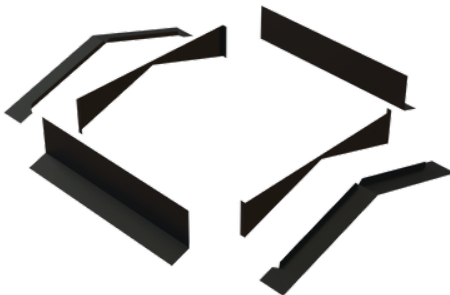

STANDARD FLASHING KIT

Model: C241/C361/C481

- 6-piece standard flashing kit
- Specific roof pitch must be ordered
- Wood support curb is field fabricated
- Ships knocked down

PREMIUM FLASHING KIT

Model: C241P/C361P/C481P/C661P

- 10-piece premium flashing kit (includes drip edge)
- Specific roof pitch must be ordered
- Wood support curb is field fabricated (Frame is 3 1/2" higher than standard)
- Ships knocked down

UNIVERSAL BASE

- Factory assembled base that requires no wood curb
- The Universal Base ships with enclosed top for non-vented applications but can also be requested as vented

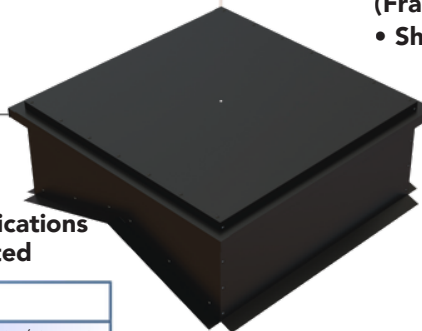

UNIVERSAL BASE

- Mounts on top of steel roofing or purlins
- Both new construction and retrofits utilize the same base
- 50+ powder coat colors available
 - For colors outside our powder coat color offering, flashing sets are available for pitches 1/12-7/12 (fasten flashing set to the universal base on site)

PITCH	MODEL #
1/12 -	
7/12 7+/12	C242/C362/C482/C662
- 12/12	C242HP/C362HP/C482HP

Also available: wind kits, curb caps, bird screen (hardware cloth) & custom color window grids.

LARGE Cupolas

- ◆ 18 ga. welded frame; Pre-painted roof & wall louvers
- ◆ Roof and sides assembled at the factory
- ◆ 66" square height w/ louvers is 80.5"; 66" square height w/windows is 84" (w/out weathervane); 48" octagon height is 77" & the 84" is 134 1/8" (louvers or windows; w/out weathervane)
- ◆ Flashing trim is available from MWI. With flashing sets, the mounting curb is made on site by the contractor (build your own wooden curb)
- ◆ Universal base also available. Ships assembled separate of the roof and side assembly. Eliminates the need to have to build your own wooden curb onsite



Assembly Video



66" square cupola w/ louved sides

MORE INFO



24" square cupola w/ windows & premium flashing

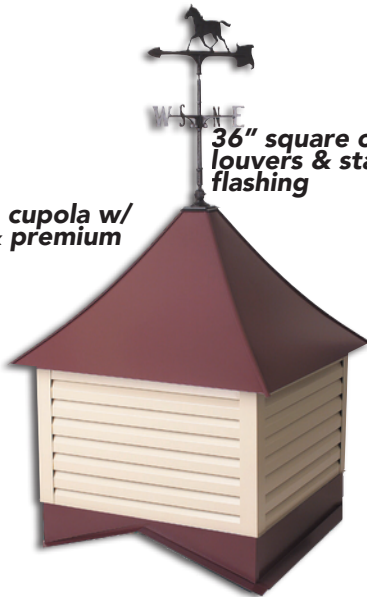

36" square cupola w/ louvers & standard flashing



48" octagon cupola w/ windows & premium flashing

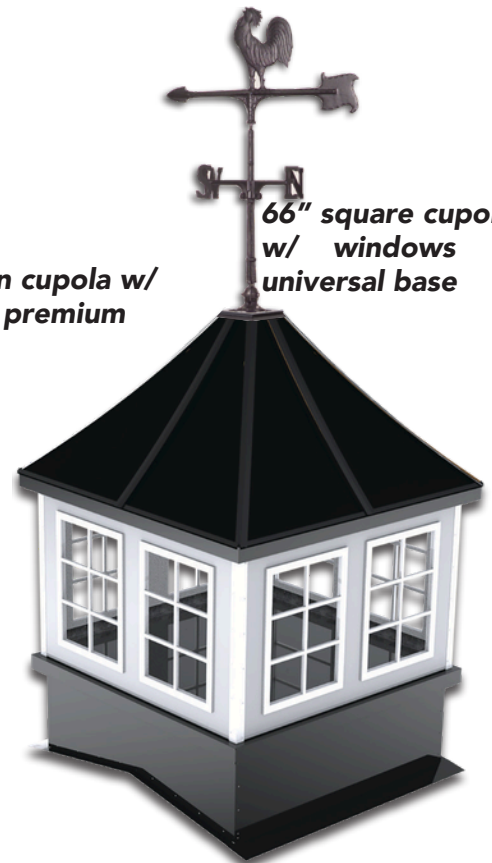

66" square cupola w/ windows & universal base

BASE SIZE	24" x 24" Square	36" x 36"	48" x 48" Square	66" x 66" Square	48" Octagon	84" Octagon
WINDOW GRIDS	2 x 2	Square 3 x 2	3 x 2	2 x 3	2 x 4	2 x 5
TOTAL HEIGHT (without base)	32.5"	48"	67-3/8"	80.5" w/ louvers 84" w/ windows	77"	134 1/8"
BUILDING WIDTH*	24' - 30'	36' - 40'	48' - 60'	User Defined	User Defined	User Defined
BUILDING LENGTH*	24' on Center	36' on Center	48' on Center	User Defined	User Defined	User Defined
WEATHERVANE*	24" or 30"	30"	46"	46" or larger	46" or larger	46" or larger

***Recommended; Contact DST for details • Building width determines cupola size. • Building length determines cupola quantity • On Center: measures the center of one cupola to the center of the next. Ex: (2) 24" cupolas will measure 24' from the center of one cupola to the center of the next on a building roof.**

MWI Weathervanes

Special Order

Louvers and/or Window

Optional Base Trims:



Copper, Gallery Blue, Light Brown

Available Sizes

24" 36" 48"

Universal Base

*Base Flash Kit (4/12)



24" Eagle



24" Horse



24" Rooster

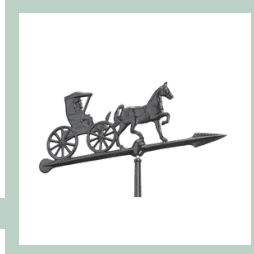

24" Country Doctor

24"

Use on 24" cupolas only

30"

Use on any cupolas



30" Duck



30" Horse



30" No Ornament



30" Pheasant



30" Pig



30" Rooster



30" Antique Auto



30" Buck



30" Country Doctor



30" Cow



30" Eagle



46" Eagle



46" Horse



46" Rooster

46"

Use on 48" cupolas or larger

46" weathervanes are 3-D/full-bodied

MWI Weathervanes (Cont.)

30" Special Order Weathervanes



Airplane



Clipper



Schooner



Cat



Horse



Mare & Colt



Fire Wagon



Motorcycle



Train



Golfer



Liberty Flag



Lighthouse



Bear



Cardinal



Trout



German Shepherd



Lab



Golden Retriever



Blue Heron



Hummingbird



Loon



Deer in Pines



Elk



Moose

Recommended Sizes

CUPOLA SIZE	24"	36"	48"	66"	48" Octagon
WEATHERVANE*	24" or 30"	30"	46"	46" or Larger	46" or Larger

Sliding Door Tracks ~

Drop Ship Charges May Apply

2200 Series

3300 Series

All Colors Available (In Stock is White)

Box Track w/ Bracket - Galvanized

SLBOX1510 - 10'

SLBOX1512 - 12'

SLBOX1514 - 14'

SLBOX1516 - 16'

SLBOX1518 - 18'

1-1/2"

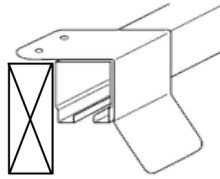

Vertical Side Rail

SLVERSR1510 - 10'

SLVERSR1512 - 12'

SLVERSR1514 - 14'

SLVERSR1516 - 16'

SLVERSR1518 - 18'

1-1/2"

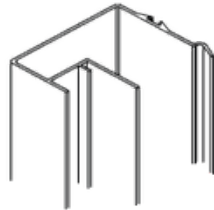

Vertical Rail w/ H-Closure

SLVERHR1510 - 10'

SLVERHR1512 - 12'

SLVERHR1514 - 14'

SLVERHR1516 - 16'

SLVERHR1518 - 18'

1-1/2"

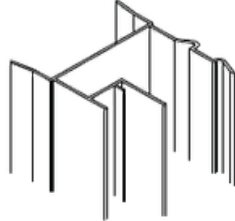

Bottom Stay Rail (Use with TBSG Bottom Stay Guide)

SLBOTSR1510 - 10'

SLBOTSR1512 - 12'

SLBOTSR1514 - 14'

SLBOTSR1516 - 16'

SLBOTSR1518 - 18'

1-1/2"

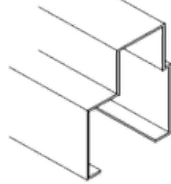

Girts - Galvanized

SLGIR10 - 10'

SLGIR12 - 12'

SLGIR14 - 14'

SLGIR16 - 16'

SLGIR18 - 18'

1-1/2" x 3-1/2"

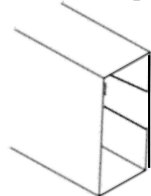

SPECIAL ORDER

Bottom Rail

(3-1/2" Use SLBOTSR35)

SLBOTR1510 - 10'

SLBOTR1512 - 12'

SLBOTR1514 - 14'

SLBOTR1516 - 16'

SLBOTR1518 - 18'

1-1/2"

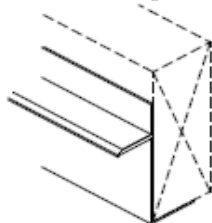

*** Round Track SPECIAL ORDER **3-1/2"**

SLVERSR3510 - 10'

SLVERSR3512 - 12'

SLVERSR3514 - 14'

SLVERSR3516 - 16'

SLVERSR3518 - 18'

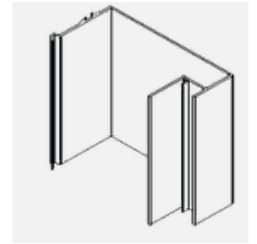

3-1/2"

SLVERHR3510 - 10'

SLVERHR3512 - 12'

SLVERHR3514 - 14'

SLVERHR3516 - 16'

SLVERHR3518 - 18'

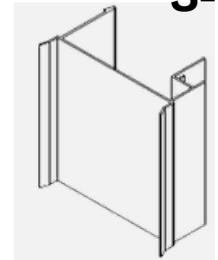

3-1/2"

SLBOTSR3510 - 10'

SLBOTSR3512 - 12'

SLBOTSR3514 - 14'

SLBOTSR3516 - 16'

SLBOTSR3518 - 18'

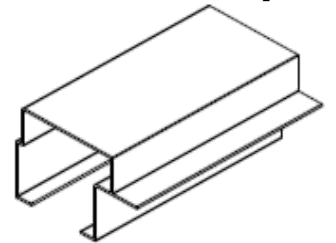

3-1/2" x 1-1/2"

SPECIAL ORDER

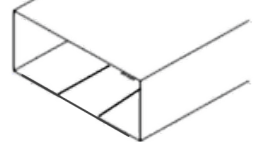

SLGIR10 - 10'

SLGIR12 - 12'

SLGIR14 - 14'

SLGIR16 - 16'

SLGIR18 - 18'

TBSG Bottom Stay Guide 1-1/2" or 3-1/2"

SLBOTSG6 - 6'

SLBOTSG8 - 8'

SLBOTSG10 - 10'

SLBOTSG14 - 14'

SLBOTSG16 - 16'

Guide should be more than 1/2 the width of door

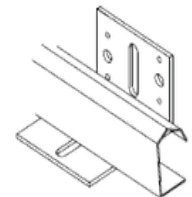

Sliding Door Accessories

SLTSA9 - 9-1/2" Adjustable Square Track Trolley Hanger (Set of 2)



SLTR9 - 9-1/2" Round Track Trolley Hanger (Set of 2)



For Larger Doors Add Extra Sets

SLUNIJAMLATCH- 7" Universal Jamb Latch (Set of 2)



SLDOORPULL- 8" White Door Pull



Universal Hook Up to to 7"

SLCENLATCH- Center Latch (Bi-Parting Doors)



SLHDSTAYROLL- Heavy Duty Stay Roller



SLCENCHLOCK- Center Chain Lock



SLCDG15 - 1-1/2" Center Door Guide



SLHDADJDRSTOP Heavy Duty Adjustable Door Stop



SLCDG35 - 3-1/2" Center Door Guide



Up to 4-1/4" Door Thickness

SLJAMMOUNT- Jam Mount Stop



Universal Stop for any door thickness

Commercial Doors -Harvard Products Inc.



Full 1-3/4" thick (R-12) fully insulated panel
 Prehung 4 way universal swing
 26 Ga. steel door skins
 Available in white
 Three fixed-pin Stainless Steel hinges with reinforced plates
 3 1/2" - 16 Ga. pre-finished steel frame

Nylon lockset insert

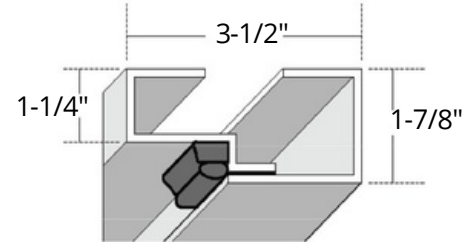
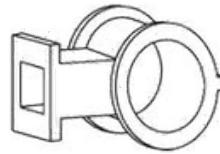

16 Ga. Steel Frame

OPTIONS

Call for color availability Windows Plain or 9 Lite
 Dead bolt lockset Door closer Double door with astragal 24 Ga. steel door skins 1/2" Threshold meets handicap specifications

DHCOM 1KD Satin Chrome Finish, Commercial Lever-Lock, Cylindrical Lockset Grade 2

DHLL2KA/KD - Satin Chrome Finish, Heavy Duty Lever-Lock, Tubular Lockset Grade 2

DHLL2PA - Satin Chrome Finish, Heavy Duty Passage Lever Grade 2



Shur-Latch ~ Stainless Steel (Special Order)

SHURLATCH-MDI

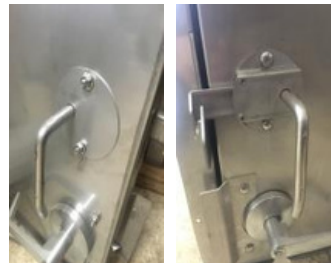

Windows & Accessories (Special Order)

Window Kits For Doors

22" x 30" 1 Lite Window

22" x 30" 9 Lite Window

16" x 16" 1 Lite Window

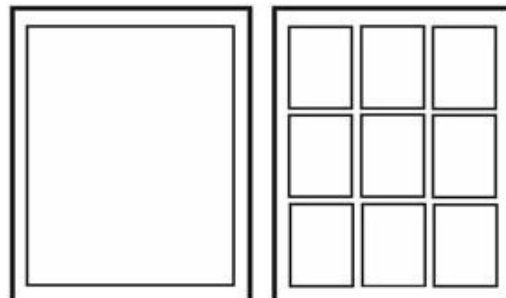

Commercial Doors -Harvard Products Inc.

SS Hinges. 16 ga. pre-painted steel jambs. 26 ga pre-painted door panel. Universal 4-way swing. Nylon lockset insert. Three fixed stainless steel pin hinges. Adjustable strike plate. Actual Unit Size is 38-5/8"x80-5/8".

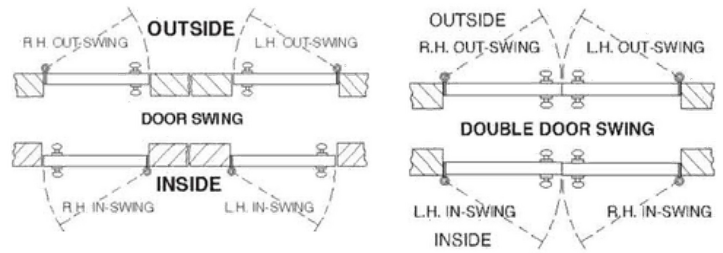

AS3 2/8x6/8 Doors

AS32868 - No Window

AS328681616 - 16" x 16" 1 Lite Window

AS328682230 - 22" x 30" 1 Lite Window

AS3286822309L - 22" x 30" 9 Lite Window

Actual Size for 2/8 door

34-5/8" x 80-5/8"

Rough Opening 35" x 81"

Special Order

Special Order

Special Order

AS3 3/0x6/8 Doors

AS33068 - No Window

AS330681616 - 16" x 16" 1 Lite Window

AS330682230 - 22" x 30" 1 Lite Window

AS3306822309L - 22" x 30" 9 Lite Window

Actual Size for 3/0 door

38-5/8" x 80-5/8"

Rough Opening 39" x 81"

AS3 4/0x6/8 Doors

AS34068 - No Window - In Stock

AS340681616 - 16" x 16" 1 Lite Window

AS340682230 - 22" x 30" 1 Lite Window

AS3406822309L - 22" x 30" 9 Lite Window

Actual Size for 4/0 door

48-5/8" x 80-5/8"

Rough Opening 49" x 81"

Special Order

Special Order

Special Order

AS3 6/0x6/8 Doors

AS36068DD - No Window

AS3606822301 - 1-22" x 30" 1 Lite Window

AS3606822309L1 - 1-22" x 30" 9 Lite Window

AS3606822302 - 2-22" x 30" 1 Lite Window

AS36068223029L - 2-22" x 30" 9 Lite Window

Actual Size for 6/0 door

74-7/8"x81-3/8"

6/0 doors with one window
specify on what panel you want the window.

Rough Opening 75-1/4" x 81-5/8"

Special Order

Special Order

Special Order

Special Order

Special Order

Upswing Doors (For load-outs)

AS32868US - 2/8x6/8 Door

AS33068US - 3/0x6/8 Door

AS34068US - 4/0x6/8 Door

Special Order

Special Order

Special Order

T-8 3/0x6/8 Thermal Door

AS3T83068 - No Window

AS3T830682230 - 22" x 30" 1 Lite Window

AS3T8306822309L - 22" x 30" 9 Lite Window

Actual Size 38-5/8" x 80-5/8"

Full thermal break of jambs, header/threshold and panel.

SS Hinges. 16 ga. pre-painted steel jambs. **24 gauge** pre-painted door panel. **Full perimeter weather stripping.** Universal 4-way swing. Nylon lockset insert. Three fixed stainless steel pin hinges. Adjustable strike plate. Actual Unit Size is 38-5/8"x80-5/8".

Special Order

Special Order

Special Order

Special Order

Special Order

Special Order

T-8 4/0x6/8 Thermal Door

AS3T84068 - No Window

AS3T840682230 - 22" x 30" 1 Lite

Window **AS3T8406822309L** - 22" x 30"

9 Lite Window

Stainless Steel Doors -Sharp Industries Inc.

Features:

- 100% 304 Stainless Steel
- 4-way universal swing
- 1-3/4" thick door with 20 Ga. skins
- 3-1/2", 16 Ga. stainless steel jambs (2"x4" walls)
- Full perimeter weather-stripping
- Standard or Custom door sizes
- Stainless steel lockset insert, reinforced 12 Ga. stainless steel plates
- Flange built into one side of frame with flange built into trim pieces on other side. Benefit is there is no need to trim after installation
- Four stainless steel hinges with bearings, reinforced 12 Ga. stainless steel plates
- Fully insulated 2-part polyurethane closed cell material injected in door which repels moisture, mold, and bacteria from spreading
- Door is prepped for lockset by boring a 2-1/8" diameter hole with a 2-3/4" backset and a 1" edge bore



Four stainless steel hinges



Weather-stripping

Options:

- 16" x 16" 1 lite, consisting of 2 pieces of 1/8" tempered glass with 1/2" dead air space
- 22" x 30" 1 lite, consisting of 2 pieces of 1/8" tempered glass with 1/2" dead air space
- Dead bolt lockset
- 5-1/2", 16 Ga. stainless steel jambs (2"x6" walls)
- Custom assemblies available in a wide range of sizes, configurations and jamb depths
- Customizable for your latch preference



Tempered glass window



Customizable for your latch preference



Dead bolt lockset

Specify 2x4 or 2x6 Wall Flange Mount or Flangeless Frame Call for Price and Custom Sizes
3068SS 4068SS 6068SS 16x16 or 22x30 Window

Rough opening is 2" wider than door and 2-1/4" taller than door
*** Freight is separate charge

Stainless Steel Doors -Sharp Industries Inc.

FEATURES:

- 100% 304 Stainless Steel
- 1-3/4" thick door with 20 Ga. Skins
- 3-1/2", 16 Ga. stainless steel jambs (2"x4" walls)
- Full perimeter weather-stripping
- Flange built into one side of frame with flange built into trim pieces on other side. Benefit is there is no need to trim after installation
- 3 stainless steel hinges with bearings, reinforced 12 Ga. stainless steel plates
- Fully insulated 2-part polyurethane closed cell material injected in door which repels moisture, mold, and bacteria from spreading
- Rough Opening is 2 inches wider and 2 1/4" inches taller than door size. Example – A 36"x80" door will have a R.O. of 38" x 82 1/4"
- Sizes available (all 80" tall) – 36", 42", 44", 48"
- Lock pin and D-ring hardware included with door



OPTIONS:

- 16" x 16" 1 lite, consisting of 2 pieces of 1/8" tempered glass with 1/2" dead air space
- 5-1/2", 16 Ga. stainless steel jambs (2"x6" walls)



Stainless Steel Door Hinges

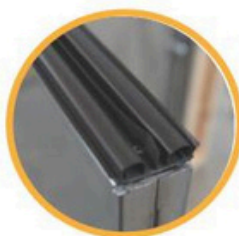

Weather-Stripping

FEATURES:

- Polypropylene Copolymer panel
- 100% 304 Stainless Steel frame, hinges, and panel retainers
- 3-1/2", 16 Ga. Stainless steel jambs (2"x4" walls)
- 2" thick door
- Flange built into one side of frame with flange built into trim pieces on the other side. Benefit is there is no need to trim after installation
- Four stainless steel hinges with bearings, reinforced 12 Ga. stainless steel plates
- Rough Opening is 2 inches wider and 2 1/4" inches taller than door size. Example – A 36"x80" door will have a R.O. of 38" x 82 1/4"
- Available sizes – 24" x 80" and 36" x 80"
- 2 way barbed door seal
- Poly Doors do not have door sweeps

OPTIONS:

- 16" x 16" 1 lite, consisting of 2 pieces of 1/8" tempered glass with 1/2" dead air space
- 5-1/2", 16 Ga. stainless steel jambs (2"x6" walls)
- Barn latch specifically made for Poly doors



Stainless Steel Door Hinges



Weather-Stripping

45 Year Limited Paint Warranty

Dakota Steel and Trim is pleased to present to you the following Limited Warranty on our Maxx Shield 45 Siliconized Polyester coil coatings. This warranty is based on the Maxx Shield 45 paint system. This warranty applies if any of the following Warranty Conditions occurs:

- Within 45 years from date of installation, Maxx Shield 45 exhibits cracking, flaking, or peeling (loss of adhesion) to an extent that is apparent on ordinary outdoor visual observation.
- Within 30 years from the date of installation, Maxx Shield 45:
 - Chalks in excess of ASTM D-4214 method A number six (6) rating on horizontally installed (roofing) panels and a number eight (8) rating on vertically installed (sidewall) panels, when properly maintained as described herein, and
 - Changes color more than seven (7.0) Hunter delta-E units on horizontally installed (roofing) panels and five (5.0) Hunter delta-E units on vertically installed (sidewall) panels as determined by ASTM method D-2244. Color changes may not be uniform on surfaces that are not equally exposed to the sun and elements and Dakota Steel does not warranty that color changes will be uniform.

If a Warranty condition occurs and other requirements of this Warranty are met, Dakota Steel and Trim will provide you with the following benefits:

- Replacement of the metal panels showing the Warranty Conditions. The Warranty Benefits shall not exceed the original purchase price of the affected metal panels (not including any accessories or attachments) or the remedy provided in any other warranty provided to the building owner, whichever is less, even if our limited warranty fails of its essential purpose. This Warranty will continue to apply to any metal panels that were replaced due to a Warranty Condition, but only for the unexpired portion of the Warranty period applicable to the original part.

Dakota Steel and Trim cannot control the circumstances of application. Therefore, this Limited Warranty applies only when Maxx Shield 45 coil coatings are properly applied to a properly pre-treated and primed substrate.

To receive Warranty Benefits for Warranty Condition, you must:

1. Send written notice of the Warranty Condition within thirty days of the appearance of any detectable defect to Dakota Steel and Trim.
2. Provide access to the affected panels and site.
3. Assist us as necessary in determining the exact cause of failure.
4. Provide such documentation as we shall request to confirm the Warranty Condition, including records sufficient to identify the steel source, production records, and installation records.

Warranty Information

45 Year Limited Paint Warranty

Dakota Steel and Trim is not responsible and provide no Warranty Benefits, for any damage or condition resulting from the circumstances beyond our control, including any of the following:

- Acts of God, falling objects, explosions, fire, external forces or other such similar or dissimilar circumstances beyond control of Dakota Steel and Trim.
- Harmful fumes or foreign substances in the atmosphere, or salt spray.
- Significant differences in insulation below coated metal panel.
- Damages due to moisture entrapment in bundles during storage or which has been stored or installed in such a way that allows standing water on the coating.
- Failures or damage resulting from corrosion at the cut/bare edges.
- Stored/installed in such a way that allows contact with animals or animal waste/confinement facilities.
- Mishandling including abuse, alteration, modification, improper use, or storage.

No warranty is provided on any substrate that is subject to sea spray or installed on property located 1,500 or fewer feet from a salt-water environment.

This warranty applies only to building parts installed on buildings within the Continental United States, Alaska, or Canada. This Warranty will automatically expire upon any change of transfer of ownership of the property on which the panel is originally installed.

This is the only warranty and except for this Warranty, WE MAKE NO WARRANTIES, EXPRESS OR IMPLIED AND DISCLAIM ALL IMPLIED WARRANTIES INCLUDING WARRANTIES OF MERCHANTABILITY OR FITNESS FOR A PARTICULAR USE OR FREEDOM FROM PATENT INFRINGEMENT. DAKOTA STEEL AND TRIM WILL NOT BE LIABLE FOR ANY SPECIAL, INCIDENTAL OR CONSEQUENTIAL DAMAGES. We have no other liability with respect to Maxx Shield 45 Siliconized coil coatings, whether based on warranty, negligence or any other legal theory.

This is the complete warranty. It lists all of Dakota Steel and Trim's obligations regarding steel panels and trims purchased. It is only for your benefit and you may not assign it to any other person or entity. Dakota Steel and Trim makes no warranty to your customers, and is not responsible for any warranty you choose to provide to your customers concerning the performance of Dakota Steel and Trim steel panels and trims. Dakota Steel and Trim may change or discontinue this Warranty by providing you with 30 days advance written notice. Any changes will only apply to Dakota Steel and Trim panels and trims after the notice period expires. This warranty shall be governed by South Dakota law, but not its conflict of law rules.

Impact Resistance: Class 4, UL 2218

Fire Test: Class A, UL 790

Uplift Resistance: Class 90, UL 580

Snow Load: Per approved engineered design of roof system and geographical location requirements.

Warranty is based on 45 year pro-rated scale subject to review by product experts and manufacturer personnel.

Notes: All substrates must be properly pretreated. Results vary by color. Warranty excludes any corrosive or aggressive atmospheres such as those contaminated with exhaust, chemical fumes, salt spray, standing water, contact by or exposure to animals or animal waste, or poorly ventilated applications. Does not cover rust which occurs at breaks or discontinuities in the surface, such as field cut edges; and shall not apply to metal penetration, cut (whether intentional or non-intentional) or shear made at any time after the product is delivered. Dakota Steel and Trim will not be liable for any special, incidental, or consequential damages. Warranties are in accordance with ASTM D3359, ASTM D2794, ASTM D2247, ASTM D659, ASTM D968, and ASTM D4060.

CONVERTING PITCH TO DEGREE

Use these charts to calculate degrees when designing custom trim. Please specify pitch when ordering.

	1:12 pitch	2:12 pitch	3:12 pitch	4:12 pitch	5:12 pitch	6:12 pitch	7:12 pitch	8:12 pitch	9:12 pitch	10:12 pitch	11:12 pitch	12:12 pitch	13:12 pitch	14:12 pitch	15:12 pitch	16:12 pitch	17:12 pitch	18:12 pitch	19:12 pitch	20:12 pitch	21:12 pitch	22:12 pitch	23:12 pitch	24:12 pitch	25:12 pitch	26:12 pitch	27:12 pitch	28:12 pitch	29:12 pitch	30:12 pitch
SINGLE SLOPE PITCHES Fascia, Eave, Endwall, Tie-In, Gutter	94°	99°	104°	108°	112°	116°	120°	123°	126°	129°	132°	135°	137°	139°	141°	143°	144°	146°	147°	149°	150°	151°	152°	153°	154°	155°	156°	156°	157°	158°
RIDGE CAP Pitch Break, Gambrel	170°	161°	152°	143°	135°	127°	120°	113°	106°	100°	95°	90°	85°	81°	77°	73°	70°	67°	64°	61°	59°	57°	55°	53°	51°	49°	47°	46°	44°	43°

TRANSITION TRIM

Find the box that intersects your lower and upper roof pitches.

If the intersection lands in the gray area, select a Lower Transition trim.

Upper Transition Trim

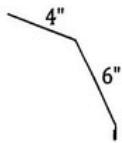

Lower Transition Trim

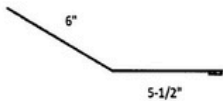

LOWER ROOF PITCH (INCHES OF RISE OVER 12" OF RUN)

	1:12 pitch	2:12 pitch	3:12 pitch	4:12 pitch	5:12 pitch	6:12 pitch	7:12 pitch	8:12 pitch	9:12 pitch	10:12 pitch	11:12 pitch	12:12 pitch	13:12 pitch	14:12 pitch	15:12 pitch	16:12 pitch	17:12 pitch	18:12 pitch
1:12 pitch		175°	171°	166°	162°	158°	155°	151°	148°	145°	142°	140°	137°	135°	133°	132°	130°	128°
2:12 pitch	175°		175°	171°	167°	163°	159°	156°	153°	150°	147°	144°	142°	140°	138°	136°	135°	133°
3:12 pitch	171°	175°		176°	171°	167°	164°	160°	157°	154°	152°	149°	147°	145°	143°	141°	139°	138°
4:12 pitch	166°	171°	176°		176°	172°	168°	165°	162°	159°	156°	153°	151°	149°	147°	145°	144°	142°
5:12 pitch	162°	167°	171°	176°		176°	172°	169°	166°	163°	160°	158°	155°	153°	151°	149°	148°	146°
6:12 pitch	158°	163°	167°	172°	176°		176°	173°	170°	167°	164°	162°	159°	157°	155°	153°	152°	150°
7:12 pitch	155°	159°	164°	168°	172°	176°		177°	173°	170°	168°	165°	163°	161°	159°	157°	155°	154°
8:12 pitch	151°	156°	160°	165°	169°	173°	177°		177°	174°	171°	169°	166°	164°	162°	161°	159°	157°
9:12 pitch	148°	153°	157°	162°	166°	170°	173°	177°		177°	174°	172°	170°	167°	166°	164°	162°	161°
10:12 pitch	145°	150°	154°	159°	163°	167°	170°	174°	177°		177°	175°	173°	170°	168°	167°	165°	163°
11:12 pitch	142°	147°	152°	156°	160°	164°	168°	171°	174°	177°		178°	175°	173°	171°	169°	168°	166°
12:12 pitch	140°	144°	149°	153°	158°	162°	165°	169°	172°	175°	178°		178°	176°	174°	172°	170°	169°

Slope Factor Chart

Running Feet	1:12 Pitch	2:12 Pitch	3:12 Pitch	4:12 Pitch	5:12 Pitch	6:12 Pitch
1	1' 0"	1' 0 1/8"	1' 0 3/8"	1' 0 5/8"	1' 1"	1' 1 3/8"
2	2' 0 1/8"	2' 0 3/3"	2' 0 3/4"	2' 1 1/4"	2' 2"	2' 2 7/8"
3	3' 0 1/8"	3' 0 1/2"	3' 1 1/8"	3' 2"	3' 3"	3' 4 1/4"
4	4' 0 1/8"	4' 0 5/8"	4' 1 1/2"	4' 2 5/8"	4' 4"	4' 5 5/8"
5	5' 0 1/4"	5' 0 7/8"	5' 1 7/8"	5' 3 1/4"	5' 5"	5' 7 1/8"
6	6' 0 1/4"	6' 1"	6' 2 1/4"	6' 3 7/8"	6' 6"	6' 8 1/2"
7	7' 0 1/4"	7' 1 1/8"	7' 2 5/8"	7' 4 1/2"	7' 7"	7' 9 7/8"
8	8' 0 3/8"	8' 1 3/8"	8' 3"	8' 5 1/4"	8' 8"	8' 11 3/8"
9	9' 0 3/8"	9' 1 1/2"	9' 3 3/8"	9' 5 7/8"	9' 9"	10' 0 3/4"
10	10' 0 3/8"	10' 1 5/8"	10' 3 3/4"	10' 6 1/2"	10' 10"	11' 2 1/8"
11	11' 0 1/2"	11' 1 7/8"	11' 4 1/8"	11' 7 1/8"	11' 11"	12' 3 5/8"
12	12' 0 1/2"	12' 2"	12' 4 3/8"	12' 7 3/8"	13' 0"	13' 5"
13	13' 0 1/2"	13' 2 1/8"	13' 4 3/4"	13' 8 1/2"	14' 1"	14' 6 3/8"
14	14' 0 5/8"	14' 2 3/8"	14' 5 1/8"	14' 9 1/8"	15' 2"	15' 7 7/8"
15	15' 0 5/8"	15' 2 1/2"	15' 5 1/2"	15' 9 3/4"	16' 3"	16' 9 1/4"
16	16' 0 5/8"	16' 2 5/8"	16' 5 7/8"	16' 10 3/8"	17' 4"	17' 10 5/8"
17	17' 0 5/8"	17' 2 7/8"	17' 6 1/4"	17' 11"	18' 5"	19' 0 1/8"
18	18' 0 3/4"	18' 3"	18' 6 5/8"	18' 11 5/8"	19' 6"	20' 1 1/2"
19	19' 0 3/4"	19' 3 1/8"	19' 7"	20' 0 3/8"	20' 7"	21' 2 7/8"
20	20' 0 7/8"	20' 3 3/8"	20' 7 3/8"	21' 1"	21' 8"	22' 4 3/8"
21	21' 0 7/8"	21' 3 1/2"	21' 7 3/4"	22' 1 5/8"	22' 9"	23' 5 3/4"
22	22' 0 7/8"	22' 3 5/8"	22' 8 1/8"	23' 2 1/4"	23' 10"	24' 7 1/8"
23	23' 1"	23' 3 3/4"	23' 8 1/2"	24' 3"	24' 11"	25' 6 3/8"
24	24' 1"	24' 4"	24' 8 7/8"	25' 3 5/8"	26' 0"	26' 10"
25	25' 1"	25' 4 1/8"	25' 9 1/4"	26' 4 1/4"	27' 1"	27' 11 3/8"
26	26' 1 1/8"	26' 4 1/4"	26' 9 1/2"	27' 5"	28' 2"	29' 0 3/4"
27	27' 1 1/8"	27' 4 1/2"	27' 9 7/8"	28' 5"	29' 3"	30' 2 1/4"
28	28' 1 1/8"	28' 4 3/4"	28' 10 1/4"	29' 6 1/4"	30' 4"	31' 3 3/4"
29	29' 1 1/4"	29' 4 7/8"	29' 10 5/8"	30' 6 7/8"	31' 5"	32' 5 1/8"
30	30' 1 1/4"	30' 5"	30' 11"	31' 7 1/2"	32' 6"	33' 6 1/2"
31	31' 1 3/8"	31' 5 1/8"	31' 11 3/8"	32' 8 1/8"	33' 7"	34' 7 7/8"
32	32' 1 3/8"	32' 5 1/4"	32' 11 3/4"	33' 8 1/8"	34' 8"	35' 9 1/4"
33	33' 1 1/2"	33' 5 1/2"	34' 0 1/8"	34' 9 3/8"	35' 9"	36' 10 3/4"
34	34' 1 1/2"	34' 5 3/4"	35' 0 1/2"	35' 10"	36' 10"	38' 0 1/4"
35	35' 1 1/2"	35' 5 7/8"	36' 0 7/8"	36' 10 5/8"	37' 11"	39' 1 5/8"

DEGREES OF BEND PER ROOF PITCH

Fascia, Eave, Endwall, Gutter		Hip, Valley		Ridgecap	
1:12	94.76 degrees	1:12	173.00 degrees	1:12	103.00 degrees
2:12	99.46 degrees	2:12	167.00 degrees	2:12	161.00 degrees
3:12	104.04 degrees	3:12	160.00 degrees	3:12	152.00 degrees
4:12	108.44 degrees	4:12	154.00 degrees	4:12	143.00 degrees
5:12	112.62 degrees	5:12	148.00 degrees	5:12	135.00 degrees
6:12	116.57 degrees	6:12	143.00 degrees	6:12	127.00 degrees
7:12	120.26 degrees	7:12	138.00 degrees	7:12	120.00 degrees
8:12	123.69 degrees	8:12	134.00 degrees	8:12	113.00 degrees
9:12	126.87 degrees	9:12	130.00 degrees	9:12	106.00 degrees
10:12	129.81 degrees	10:12	126.00 degrees	10:12	100.00 degrees
11:12	132.51 degrees	11:12	123.00 degrees	11:12	95.00 degrees
12:12	135.00 degrees	12:12	120.00 degrees	12:12	90.00 degrees

DECIMAL EQUIVALENTS

- 1/8=0.125
- 1/4=0.25
- 3/8=0.375
- 1/2=0.5
- 5/8=0.625
- 3/4=0.75
- 7/8=0.875

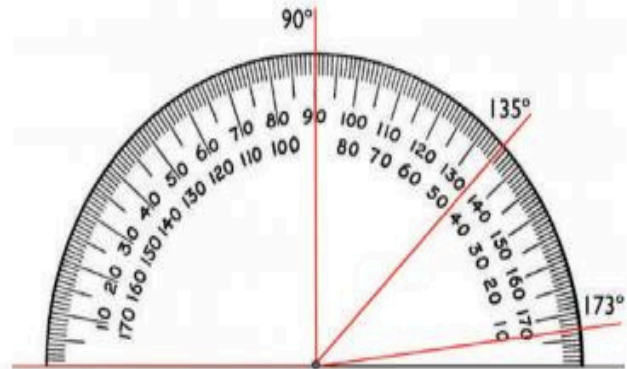

FLAT AREA MULTIPLIER

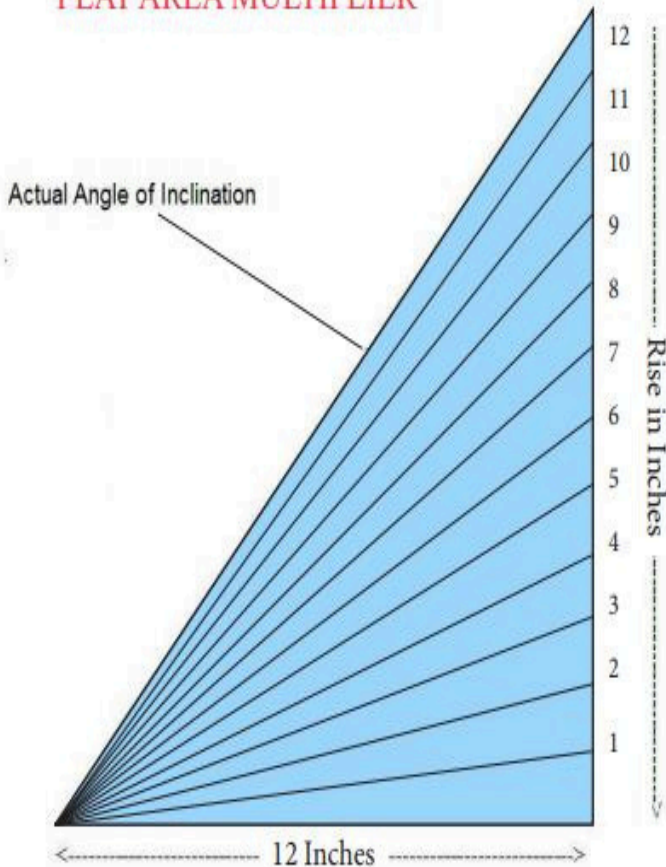

PITCH	FACTOR
2:12	1.015
3:12	1.035
4:12	1.055
5:12	1.085
6:12	1.12
7:12	1.16
8:12	1.205
9:12	1.25
10:12	1.305
11:12	1.36
12:12	1.415



CORPORATE OFFICE

29007 477TH AVE. CANTON, SD 57013



MINNESOTA PLANT

500 WHIRLWIND DR. FREEPORT, MN 56331



 866-987-9080



WWW.DAKOTASTEELANDTRIM.COM

